

SEIBERSDORF  
LABORATORIES



FREQUENTLY ASKED SOLUTIONS



**MANUAL**

**PLA - PRECISION LOOP ANTENNA**



EMC & OPTICS

# MANUAL

## PLA – Precision Loop Antenna

PLA-R	Receive Antenna
PLA-T	Transmit Antenna
PLA-TC	Transmit Antenna Control Unit
PLA-GD	Ground Loop Decoupling Unit

Applications for radiated emission testing and Site Validation

# Notice

Seibersdorf Labor GmbH reserves the right to make changes to any product described herein in order to improve function, design or for any other reason. Nothing contained herein shall constitute Seibersdorf Labor GmbH assuming any liability whatsoever arising out of the application or use of any product or circuit described herein. All graphs show typical data and not the measurement values of the individual product delivered with this manual. Seibersdorf Labor GmbH does not convey any license under its patent rights or the rights of others.

© Copyright 2025 by Seibersdorf Labor GmbH. All Rights Reserved.  
No part of this document may be copied by any means without written permission from Seibersdorf Labor GmbH

## Contact

**Seibersdorf Labor GmbH**  
EMC & Optics – RF-Engineering  
T +43(0) 50550-2882 | F +43(0) 50550-2881  
[rf@seibersdorf-laboratories.at](mailto:rf@seibersdorf-laboratories.at)  
[www.seibersdorf-laboratories.at/rf](http://www.seibersdorf-laboratories.at/rf)

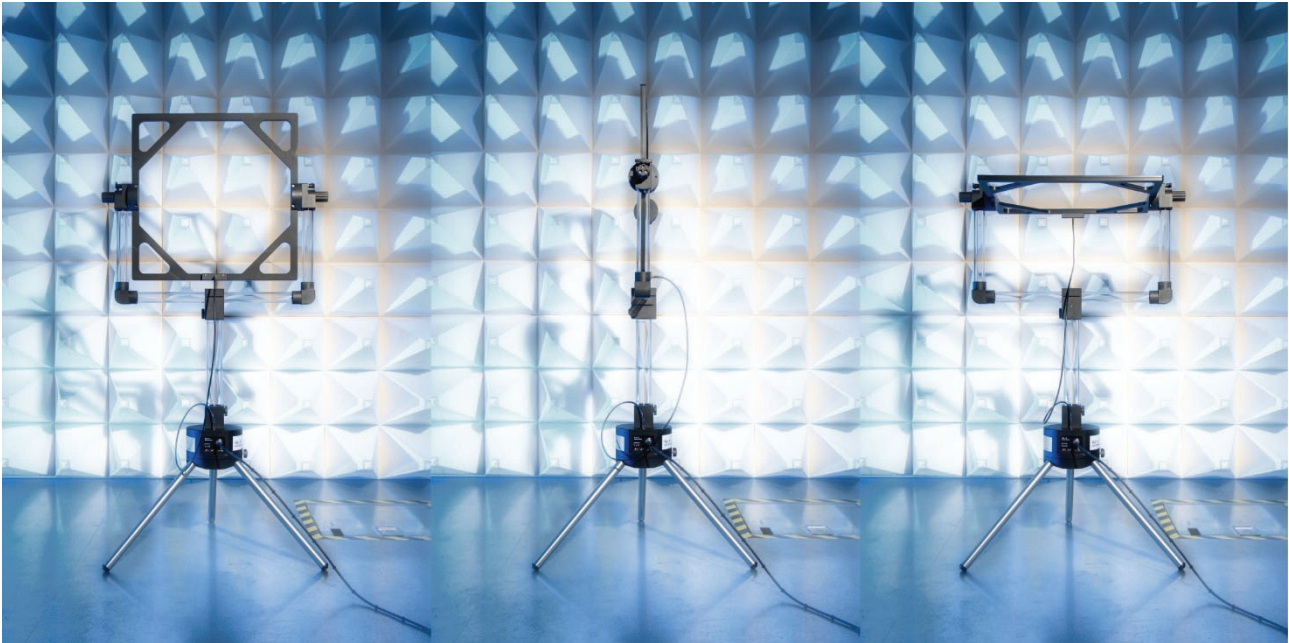
VAT no.: ATU64767504, Company no. 319187v  
Bank details: Erste Bank der Österreichischen Sparkassen AG  
IBAN AT112011129114038000  
BIC GIBAATWW

# Table of Contents

1.	Introduction .....	6
2.	Description of the Antennas .....	7
2.1.	PLA-R Receive Antenna .....	8
2.2.	PLA-T Transmit Antenna.....	11
2.3.	PLA-TC Transmit Antenna Control Unit.....	13
2.4.	PLA-GD Ground Loop Decoupling Unit .....	15
3.	Technical Specifications.....	16
3.1.	PLA-R Receive Antenna .....	16
3.2.	PLA-T Transmit Antenna.....	20
3.3.	PLA-TC Transmit Antenna Control Unit.....	22
3.4.	PLA-GD Ground Loop Decoupling Unit .....	23
3.5.	Charger .....	24
4.	Installation and Operation .....	25
4.1.	PLA-R receive antenna set components.....	26
4.2.	PLA-T transmit antenna set components.....	26
4.3.	Assembly of PLA-T and PLA-R.....	27
4.4.	Laser alignment system .....	29
4.5.	Polarization Change.....	30
4.6.	Maintenance .....	33
5.	Applications.....	34
5.1.	Normalized Site Insertion Loss .....	34
5.2.	Shielding Effectiveness .....	40
5.3.	Radiated Disturbance.....	42
6.	Calibration.....	44
6.1.	Calibration of the individual antenna factor .....	44
6.2.	Calibration of the antenna pair .....	45
6.3.	Calibration of the antenna pair reference.....	46
7.	Literature and information .....	47
ANNEX I.	WARRANTY .....	49
ANNEX II.	Safety against electromagnetic fields.....	50
ANNEX III.	Laser Safety .....	51
ANNEX IV.	Battery Information .....	53
ANNEX V.	NSA values for site validation.....	54
ANNEX VI.	Sample Certificate of Antenna Calibration .....	58
ANNEX VII.	Sample Certificate of Sum of Antenna Factors .....	62

# 1. Introduction

The **Precision Loop Antennas (PLA)** were developed by Seibersdorf Laboratories due to industry demand for an EMC test site validation system below 30 MHz and a radiated emission test antenna for 9 kHz – 30 MHz with automated overload (saturation) indication in the test software.



Active **receive** antennas for this frequency range are available since many decades but they all lack of a convenient overload indication which makes them unsuitable for fully automated tests. Design goal was a battery powered active receive antenna that detects overload of the preamplifier on all wave shapes of the RF signals and indicates this on the RF-output in a way that fully automated tests with state of the art EMI-receivers are possible (patented).

For the site validation in the frequency range 9 kHz – 30 MHz additionally a battery powered active **transmit** antenna was designed. The antenna stand integrates laser pointers for easy positioning and adjustment.

This manual describes in detail the application of the PLA for disturbance testing and site validation.

Technical specifications of the antennas are presented.

## 2. Description of the Antennas

The PLA is an active antenna system covering the frequency range 9 kHz to 30 MHz which comes in two versions for transmit and receive operation.

**PLA-R** system for receiving signals

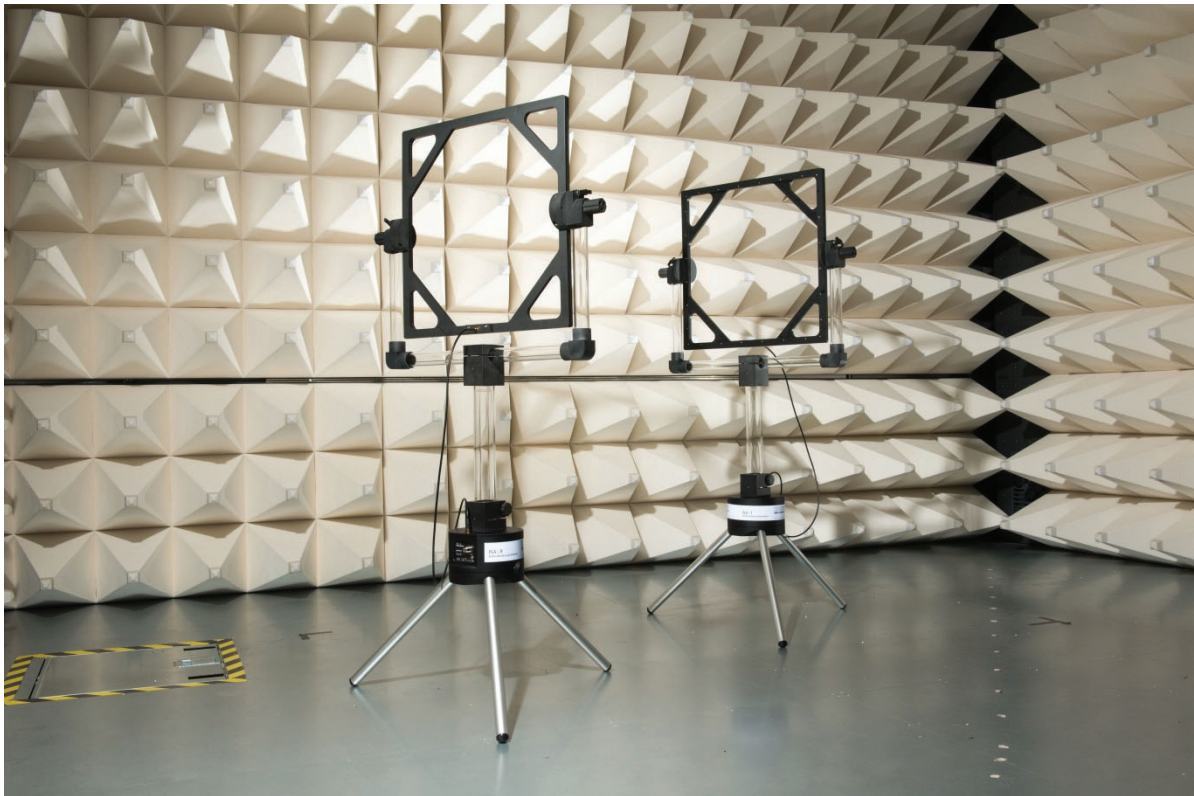
**PLA-T** system for transmitting signals

Both antennas can be operated in passive mode (without amplifier) as well.

In **Figure 1** the PLA-R and PLA-T is shown. Each antenna consists of the amplifier box which forms a tripod and the loop antenna which can be oriented in three orthogonal directions.

Both antennas are equipped with a laser alignment system for easy and convenient setup of the antennas.

The size and shape of both antennas are identical; they differ only in the amplifier box.



**Figure 1:** Transmit and Receive PLA at work

## 2.1. PLA-R Receive Antenna

The receive antenna (PLA-R) operation elements are shown in **Figure 2**. When the power is switched OFF, the middle position of the toggle switch, the system operates in passive mode.

The left position of the toggle switch, ON, sets the antenna into active mode.

In position LAS, the right position of the toggle switch, the laser alignment system is turned on. More information about the laser alignment system can be found in chapter 4.4.



**Figure 2:** PLA-R amplifier box

A second toggle switch is used to turn ON and OFF the pulse generator. The third position TEST is used to test if the detector works reliably.

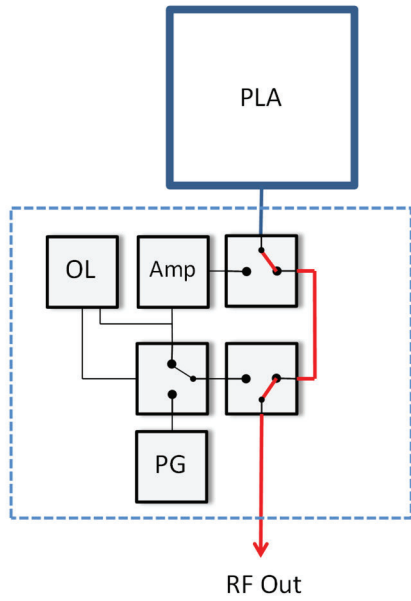
There are two LEDs to show the status of the overload detection. ACT indicates that the overload detector is armed. If the detector recognises overload the SAT LED will light up.

Three POWER LEDs indicate the battery status. A green colour indicates a normal state (charged). The yellow LED indicates that a recharge is recommended soon, but operation is still possible. If the red LED lights up, further operation is impossible and the battery must be recharged immediately.

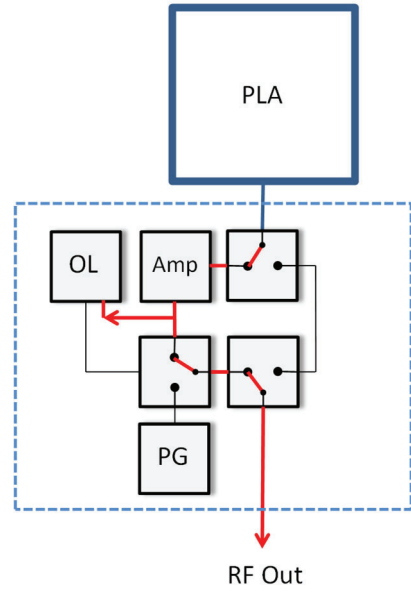
The amplifier box of the PLA-R antenna consists of an amplifier (Amp), an overload detector (OL) and a pulse generator (PG), see **Figure 3**. If the antenna is operating in passive mode, **Figure 3(a)**, the signal of the antenna is routed directly to the output connector. In active mode, **Figure 3(b)**, the signal magnitude is increased by the amplifier. If the input signal becomes too large the amplifier will be saturated. To prevent this, the overload detector will observe the output signal of the amplifier. If the overload indicator is active, a pulsed signal will be routed to the output, **Figure 4(a)**. This strong wideband signal will force the attached EMI-receiver into overload.

To test whether the detection works reliably, a test mode is provided, see **Figure 4(b)**. This is required as the overload detection of the EMI receiver depends on the bandwidth and input attenuator settings. More information on testing the reliability of the overload detection can be found in chapter 6.3.

a)



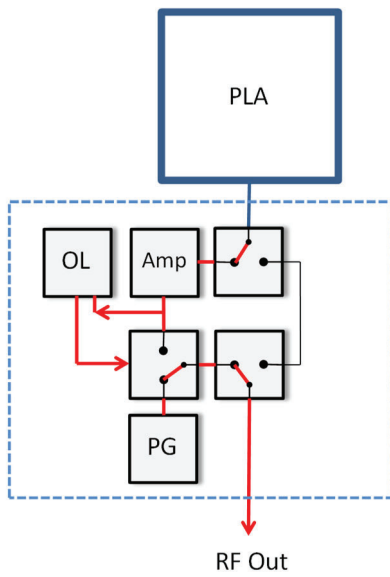
b)



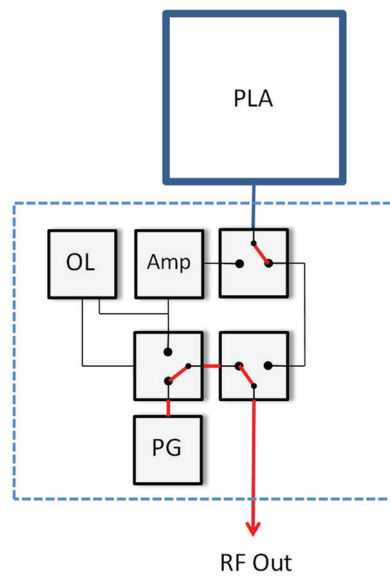
**Figure 3:** Schematic of PLA-R  
 a) passive mode  
 b) active mode, no overload detected

*Amp: preamplifier; OL: overload detection; PG: pulse generator*

a)



b)



**Figure 4:** Schematic of PLA-R  
 a) overload detected  
 b) test of pulse generator

*Amp: preamplifier; OL: overload detection; PG: pulse generator*

Depending on the application and the connected device the saturation detection (SATURATION DET) shall be active (ON) or deactivated (OFF).

**CAUTION:** Make sure that the connected receiving device is capable to withstand the pulsed signal. Specification of the pulsed signal is found in chapter 4.2

The overload detector is sensitive to single pulses also.

**CAUTION:** The overload detector may be activated during setup by switch-on currents of EUTs and ESD discharges in anechoic chambers. This is normal operation and does not indicate a failure of the PLA-R.

## 2.2. PLA-T Transmit Antenna

The transmit antenna (PLA-T) operation elements are shown in **Figure 5**. When the power is switched OFF (middle position of the toggle switch) the system operates in passive mode.

The left position of the toggle switch, ON, sets the antenna into active mode.

In position LAS (right position of the toggle switch) the laser alignment system is turned on. More information about the laser alignment system can be found a chapter 4.4.



**Figure 5:** PLA-T amplifier box

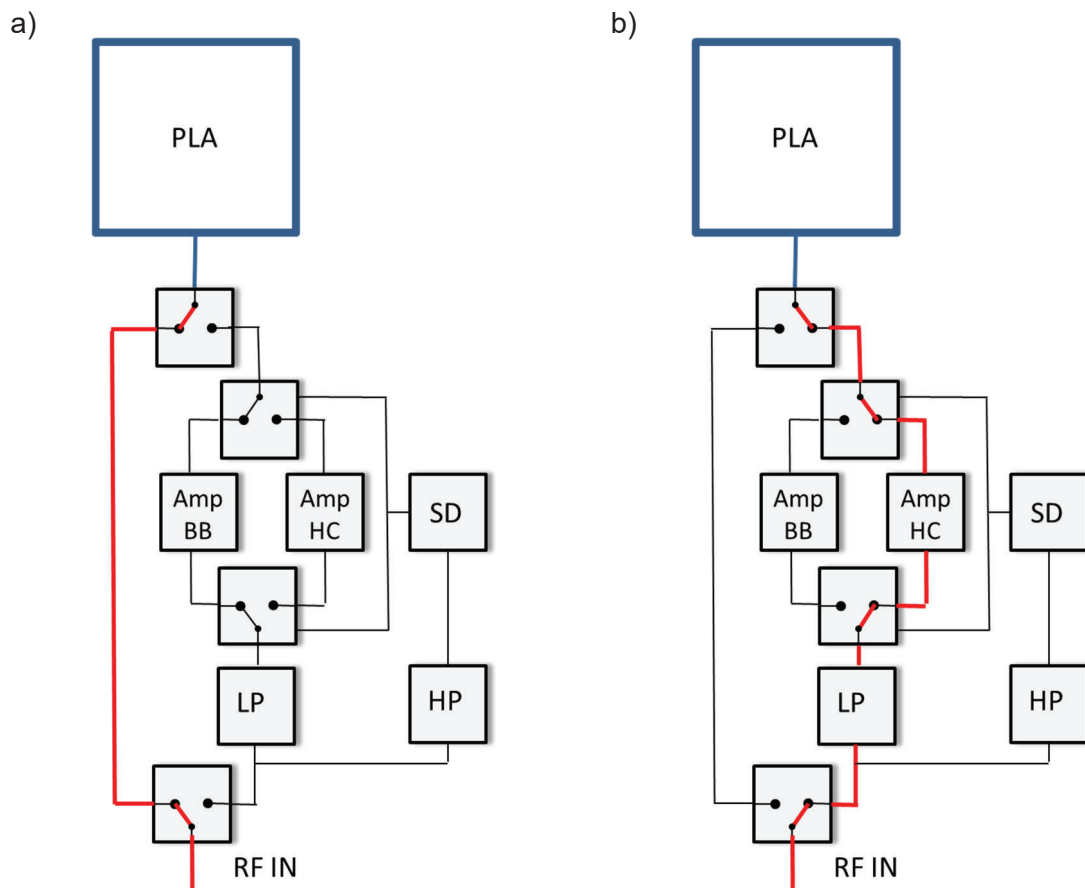
There are two LEDs to show which amplifier is active. In case of the broadband amplifier LED BB is on. For the high current amplifier the LED HC is active.

Three POWER LEDs indicate the state of the battery. Normal state (charged) is indicated by green colour. In state yellow operation is still possible, but a soon recharge is recommended. If the red LED is light up, further operation is impossible and immediate recharge is required.

Similar to the PLA-R the PLA-T has a passive mode where the signal is routed from the input connector directly to the antenna, see **Figure 6 (a)**.

If the antenna is operating in active mode and no switch signal is present the input signal is increased by the broadband amplifier, see **Figure 6 (b)**.

The amplifier box of the PLA-T antenna consists of two amplifiers: a broadband amplifier (Amp WB) and high current amplifier (Amp HC). To switch between the two amplifiers a switching signal with a frequency above the antenna frequency band is used. The presence of this signal is checked by the switch detector (SD). To separate the signals a low pass (LP) and a high pass (HP) filter are used. To switch to the high current amplifier it is necessary to feed the switch signal to the antenna, which is done by the PLA-TC transmit antenna control unit. More information about the PLA-TC can be found in chapter 2.3.



**Figure 6:** Schematic of PLA-T  
 a) passive mode  
 b) broadband amplifier mode

*Amp BB: broadband amplifier; Amp HC: high current amplifier; LP: low pass filter; HP: high pass filter; SD: switchdetector*

## 2.3. PLA-TC Transmit Antenna Control Unit

The transmit antenna control unit is required to activate the PLA-T high current amplifier in case high dynamic is required.



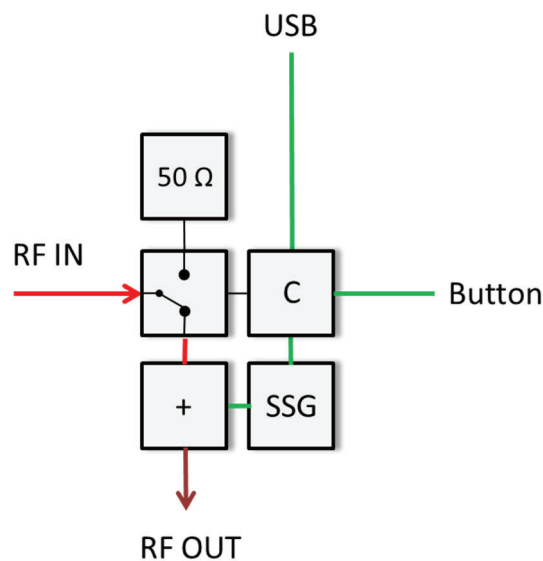
**Figure 7:** PLA-TC Transmit Antenna Control Unit

The unit has two status LEDs. The first one indicates that the unit is powered up. The second one lights up if the high current amplifier mode is switched on.

There are two possibilities to control the transmit antenna control unit:

- USB: The PLA-TC is connected to a PC via the USB cable. The switching between both modes is done via software (PLA-TC App).
- Manual: By pressing the small button next to the LEDs the PLA-TC is switched to the next mode. In the manual mode the PLA-TC can be powered by a PC or the PLA-TC power supply.

PLA-TC consists of a relay, a switch signal generator (SSG), a controller (C), a signal combiner (+) and a 50  $\Omega$  termination, see **Figure 8**.



**Figure 8:** Schematic of PLA-TC

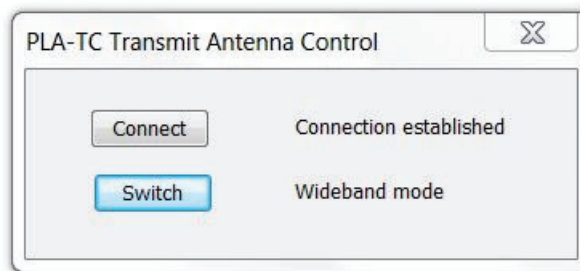
SSG: Switch Signal Generator; +: Signal combiner, C: Controller

The signal combiner adds the switch signal to the antenna cable. Since hot switching will harm the relays of the PLA-T the transmit control will switch with three steps:

- Remove the RF signal from RF OUT by switching to 50  $\Omega$  termination using the relay
- Turn on the switch signal
- Switch back the relay to RF IN

The PLA-TC App is included (see USB stick as part of the PLA - set) and requires Windows 7 or Windows 10 and USB 2.0 or higher.

After starting the PLA-TC App a connection to the PLA-TC is established by pressing the “Connect” Button. If this is successful the App will show “Connection established”. Press the switch button to switch to the next mode. The current mode is also shown.



**Figure 9:** PLA-TC App

## 2.4. PLA-GD Ground Loop Decoupling Unit

The Ground Loop Decoupling Unit is used to prevent ground loops during site validation. Ground loops are critical in the frequency range from 9 kHz to 100 kHz and can decrease the dynamic range dramatically. More information about ground loops can be found at [14].



Figure 10: PLA-GD Ground Loop Decoupling Unit

The Ground Loop Decoupling Unit consists of a RF wideband transformer and provides galvanic isolation between output and input ground, see Figure 11.

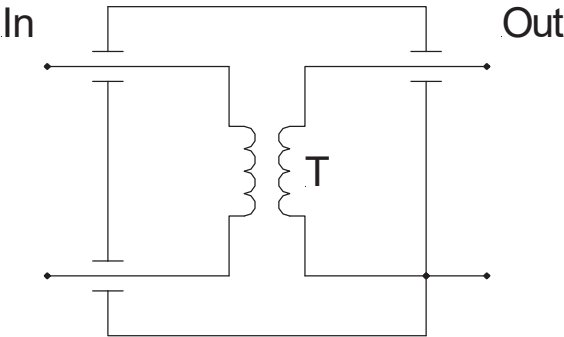


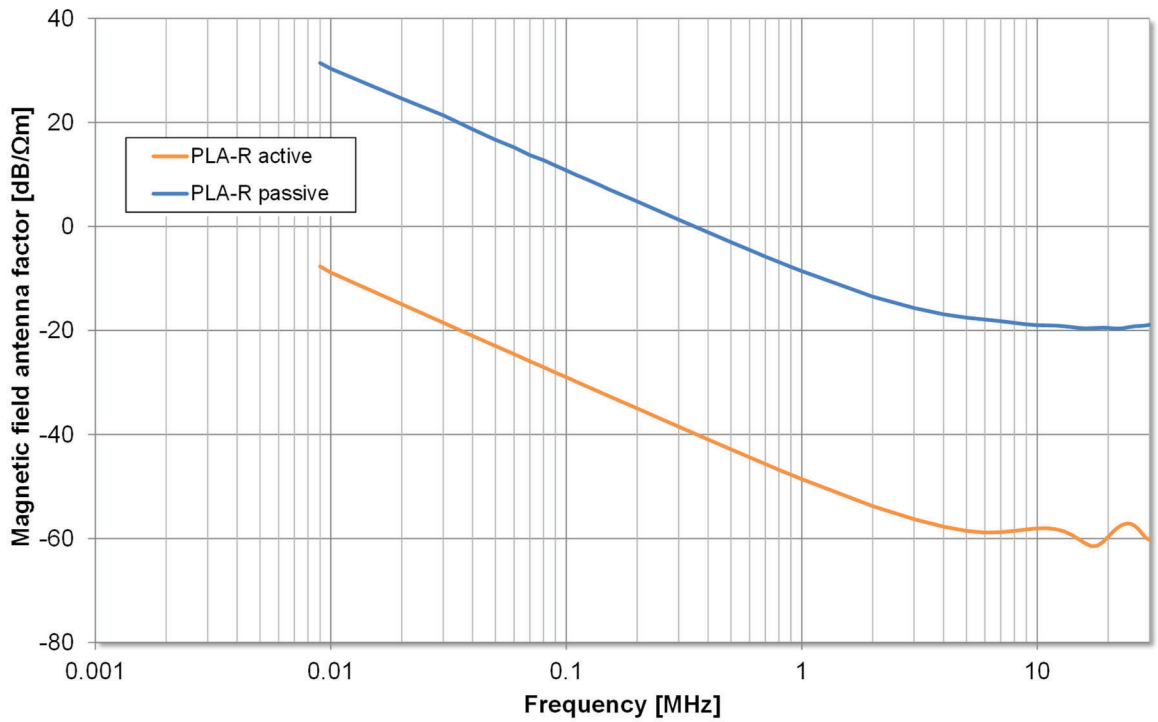
Figure 11: Schematic of PLA-GD

### 3. Technical Specifications

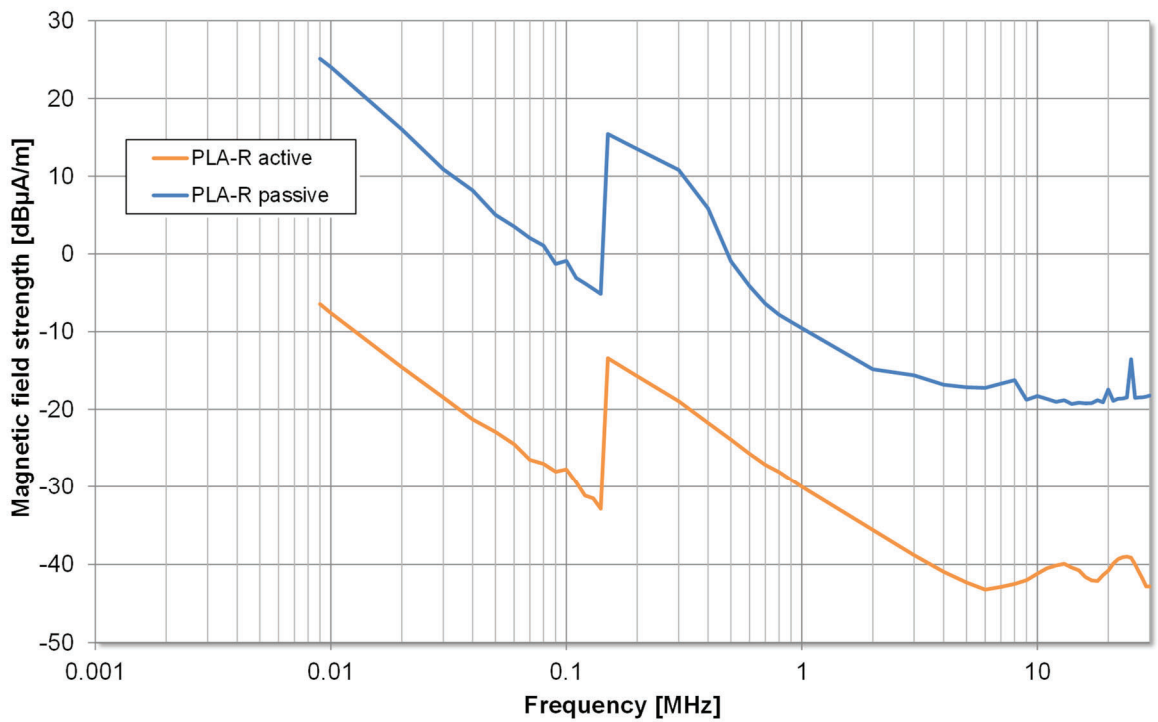
#### 3.1. PLA-R Receive Antenna

Specification	PLA-R
Frequency range	9 kHz - 30 MHz
Antenna area	Square, 60 cm side length
Antenna height (center)	1.3 m
Nominal gain of preamplifier	40 dB
Typical magnetic field antenna factor	see <b>Figure 12</b>
Antenna output VSWR (active)	<1.1
Typical noise floor	see <b>Figure 13</b>
Maximum field strength	see <b>Figure 14</b>
Saturation indication sensitive to	single pulse
Saturation indication minimum on time	3 s
Output level at maximum field strength (CW) in active mode	112 dB $\mu$ V
Cross-polarization	> 30 dB
Connector type	Type N female
Output coupling	AC
Pulse generator <ul style="list-style-type: none"> <li>• Voltage</li> <li>• Pulse repetition frequency</li> <li>• Pulse width</li> </ul> Spectrum	30 V 10 kHz, 1 MHz 200 ns, 12 ns see <b>Figure 15</b> and <b>Figure 16</b>
Temperature stability of antenna factor <ul style="list-style-type: none"> <li>• Laboratory use (20° C - 25°C)</li> <li>• Field use (10° C – 35° C)</li> </ul>	$\pm$ 0.025 dB $\pm$ 0.1 dB
Laser alignment accuracy	$\pm$ 0.5 cm $\pm$ 0.5 °
Battery operation time <ul style="list-style-type: none"> <li>• continuous use</li> <li>• Time left under condition “yellow”</li> </ul>	> 24 h > 1 h
Batteries	internal, 10 cell NiMH (12V) (factory serviceable only)
Laser class, see Annex II	2
Temperature operating range	10°C - 35°C
Weight of Antenna including tripod	12.5 kg
Dimensions of flight case	89 x 83 x 28 cm, weight 32kg

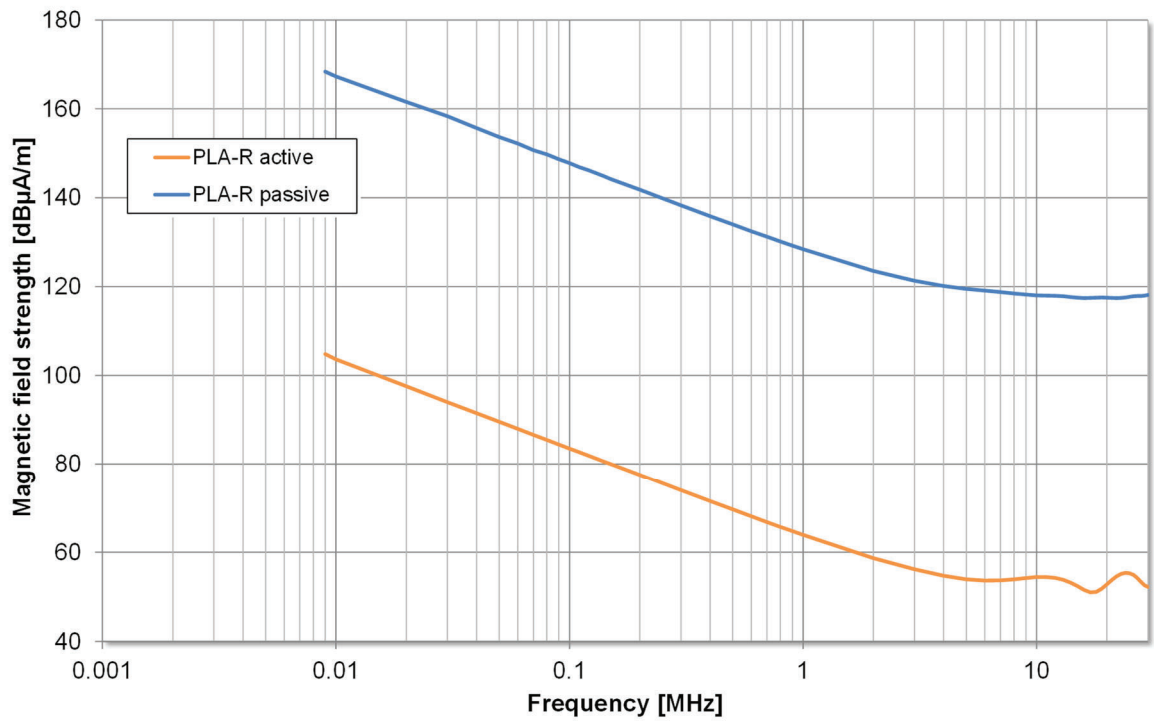
**Table 1:** Technical specifications of PLA-R



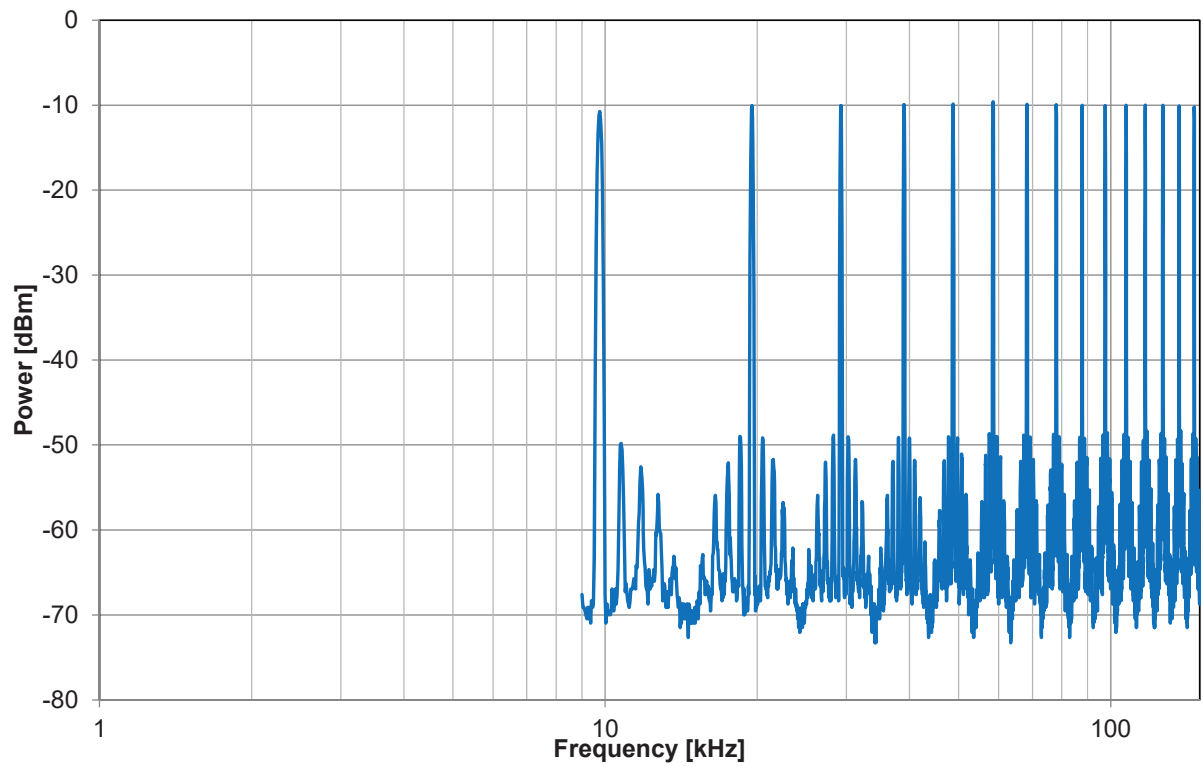
**Figure 12:** Typical magnetic field antenna factor



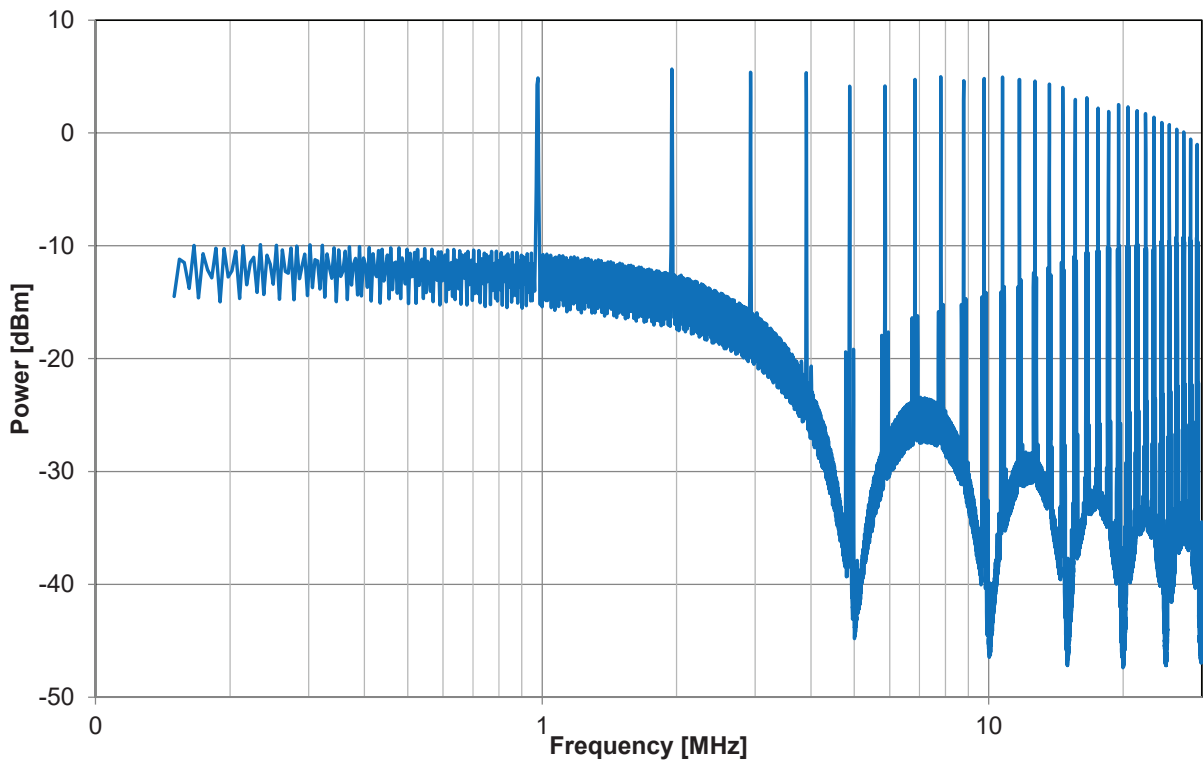
**Figure 13:** Typical noise floor measured with typical EMI Receiver, CISPR bandwidth, Quasi-Peak detector and 10 dB input attenuation



**Figure 14:** Typical maximum field strength; max. +30 dBm on RF input of EMI receiver



**Figure 15:** Spectrum of pulse generator, CISPR Band A



**Figure 16:** Spectrum of pulse generator, CISPR Band B

## 3.2. PLA-T Transmit Antenna

Specification	PLA-T	
	High current amplifier	Broadband amplifier
Frequency range	9 kHz – 200 kHz	9 kHz – 30 MHz
Equivalent output power in 50 Ω system	see <b>Figure 17</b>	
Antenna area	Square, 60 cm side length	
Antenna height	1.3 m	
Input power range	-30 dBm - -6 dBm in active mode < +46 dBm in passive mode	
VSWR (active)	<1.4 not including PLA-TC <1.1 including PLA-TC	
Typical antenna factor	see <b>Figure 18</b>	
Connector type	Type N female	
Temperature stability of antenna factor <ul style="list-style-type: none"> <li>Laboratory use (20° C – 25° C)</li> <li>Field use (10° C – 35° C)</li> </ul>	± 0.05 dB ± 0.25 dB	± 0.025 dB ± 0.15 dB
Laser alignment accuracy	± 0.5 cm ± 0.5 °	
Battery operation time <ul style="list-style-type: none"> <li>NSIL measurement typical use</li> <li>SE measurement typical use</li> <li>Time left under condition “yellow”</li> </ul>	> 12 h > 6 h > 1 h	
Batteries	internal, 10 cell NiMH (12V) (factory serviceable only)	
Laser class, see Annex II	2	
Temperature operating range	10°C – 35°C	
Weight of PLA-T Antenna including tripod	12.5 kg	
Dimensions of Antenna Set incl.flight case	89 x 83 x 53 cm, weight 62 kg	

**Table 2:** Technical specifications of PLA-T

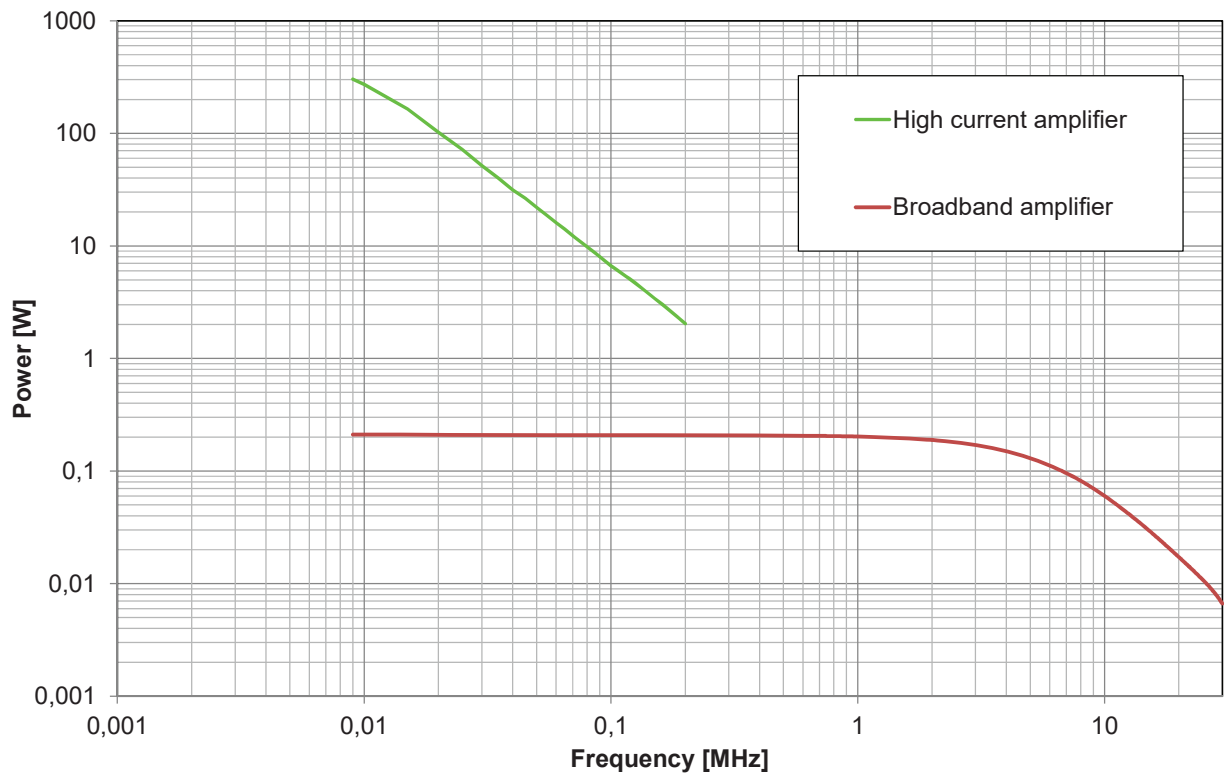


Figure 17: Typical equivalent transmit power in 50 Ω system

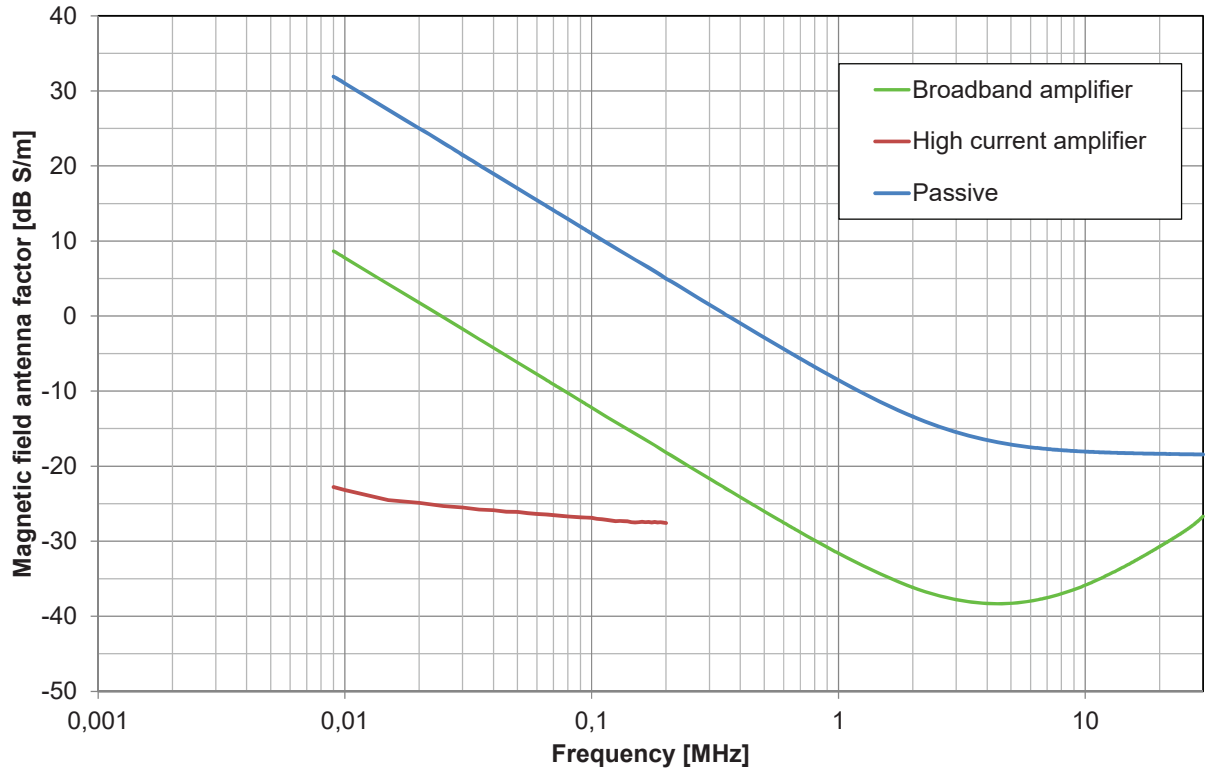
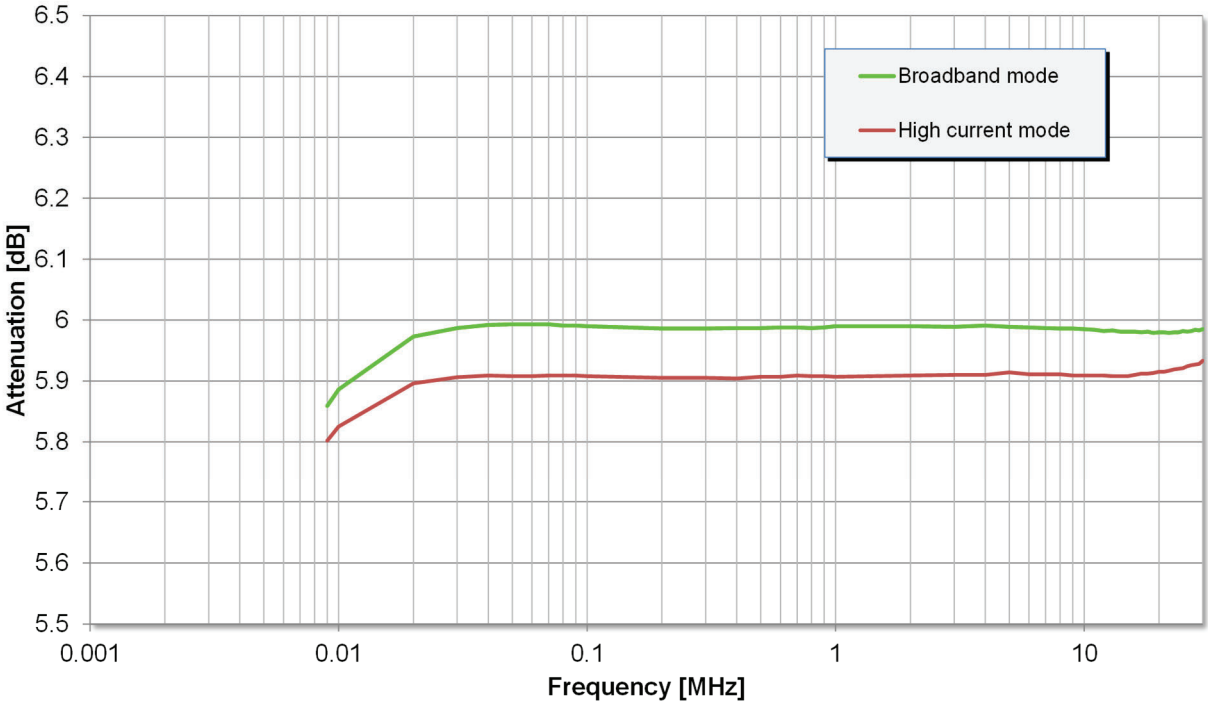


Figure 18: Typical magnetic field antenna factor

### 3.3. PLA-TC Transmit Antenna Control Unit

Specification	PLA-TC
Frequency range	9 kHz – 30 MHz
Insertion Loss	see <b>Figure 19</b>
Maximum input power	+10 dBm
USB Version	2.0
USB connector	Type B
USB power supply mode	Low power mode < 100 mA
Operating system	Windows 7, Windows 8, Windows 10
VSWR	< 1.2
Connector type	Type N female
Temperature operating range	10°C – 35°C
Dimensions	146 x 69 x 32 mm
Weight	0.235 kg

**Table 3:** Technical specifications of PLA-TC

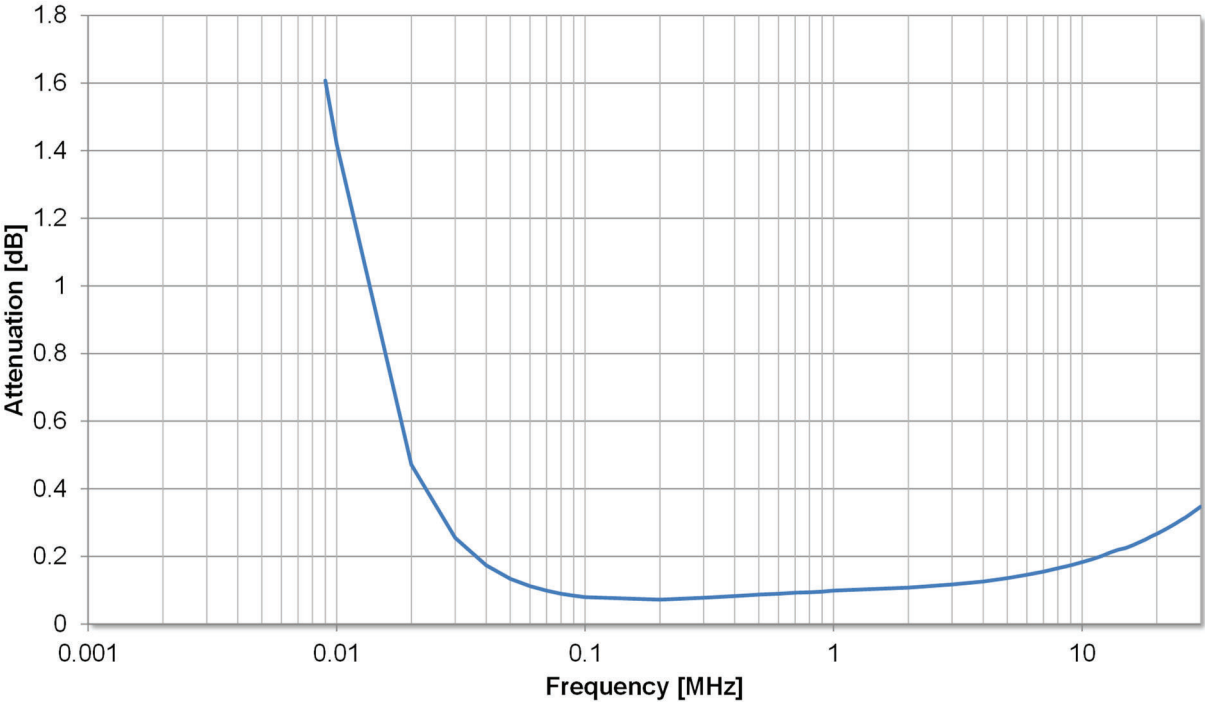


**Figure 19:** Insertion Loss of PLA-TC

### 3.4. PLA-GD Ground Loop Decoupling Unit

Specification	PLA-GD
Frequency range	9 kHz – 30 MHz
Insertion loss	see <b>Figure 20</b>
Maximum input power	+20 dBm
VSWR	< 3
Temperature operating range	10°C – 35°C
Dimensions	141 x 55 x 32 mm
Weight	0.245 kg

**Table 4:** Technical specifications of PLA-GD



**Figure 20:** Insertion Loss of PLA-GD

### 3.5. Charger

The built-in batteries of the PLA-R and the PLA-T antennas are charged with the enclosed Ansmann ACS 110 Traveller charger.



**Figure 21:** Charger

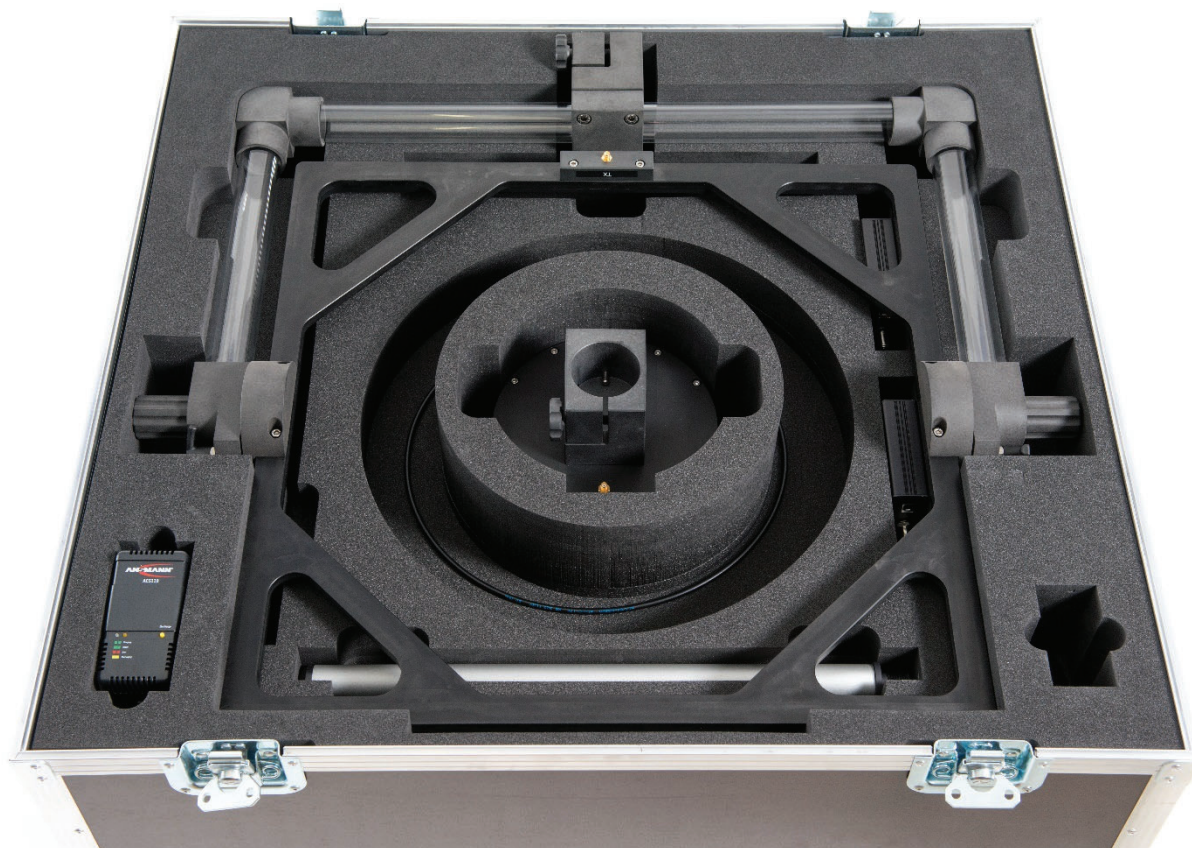
Due to the switch mode power supply and an exchangeable primary plug set, worldwide use is possible. When charging is completed, the charger automatically switches to trickle charge. Please follow the instructions of the enclosed original manual of the charger.

Specification	
Input voltage	110...240 VAC @ 50...60 Hz
Connection on the primary side	Euro, US, J, Australia primary adapters
Connection on the secondary side	coaxial plug, positive inner
Output	1.45 – 14.5 V DC, max 800 mA
Dimensions	118 x 62 x 48 mm
Weight	0.280 kg

**Table 5:** Technical specifications the charger

## 4. Installation and Operation

The antenna components are stored in a flight case for protection and easy shipment.



**Figure 22:** Flight case with PLA elements

### 4.1. PLA-R receive antenna set components

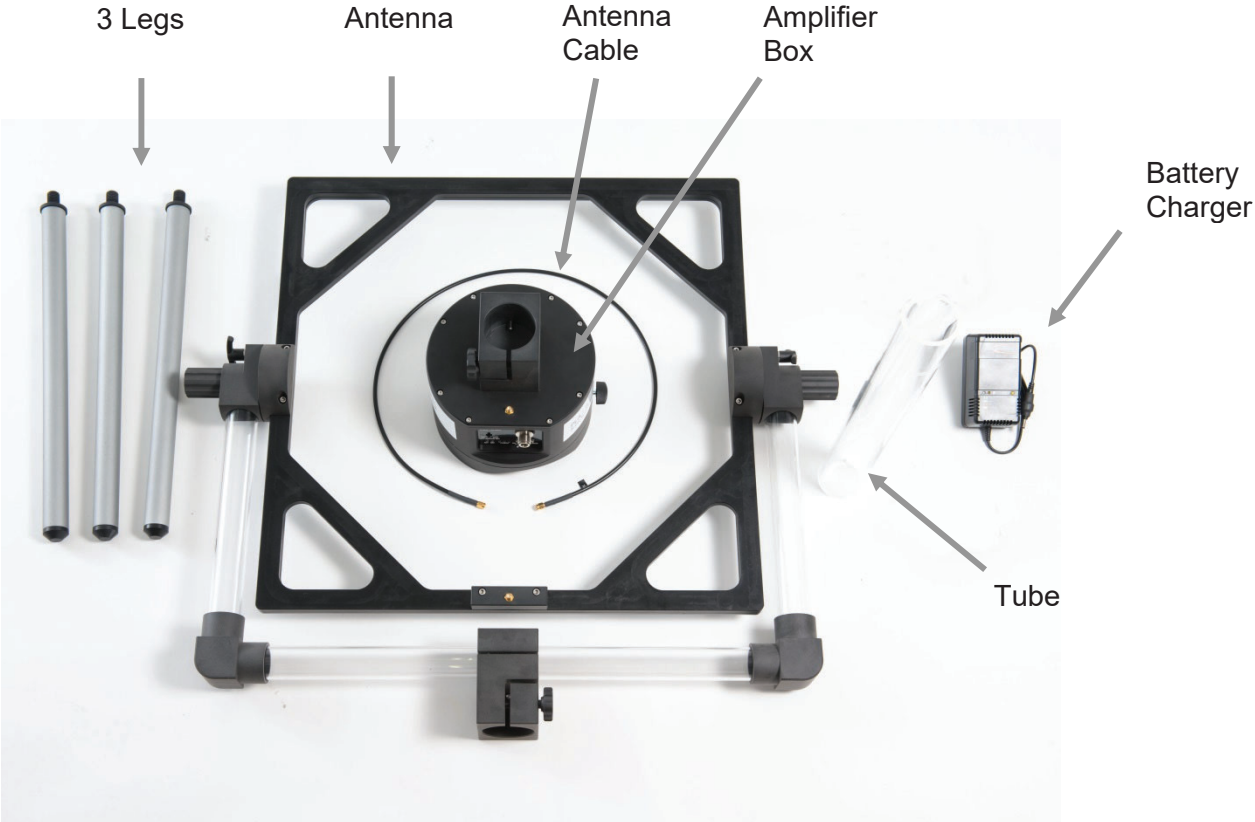


Figure 23: PLA-R components

### 4.2. PLA-T transmit antenna set components

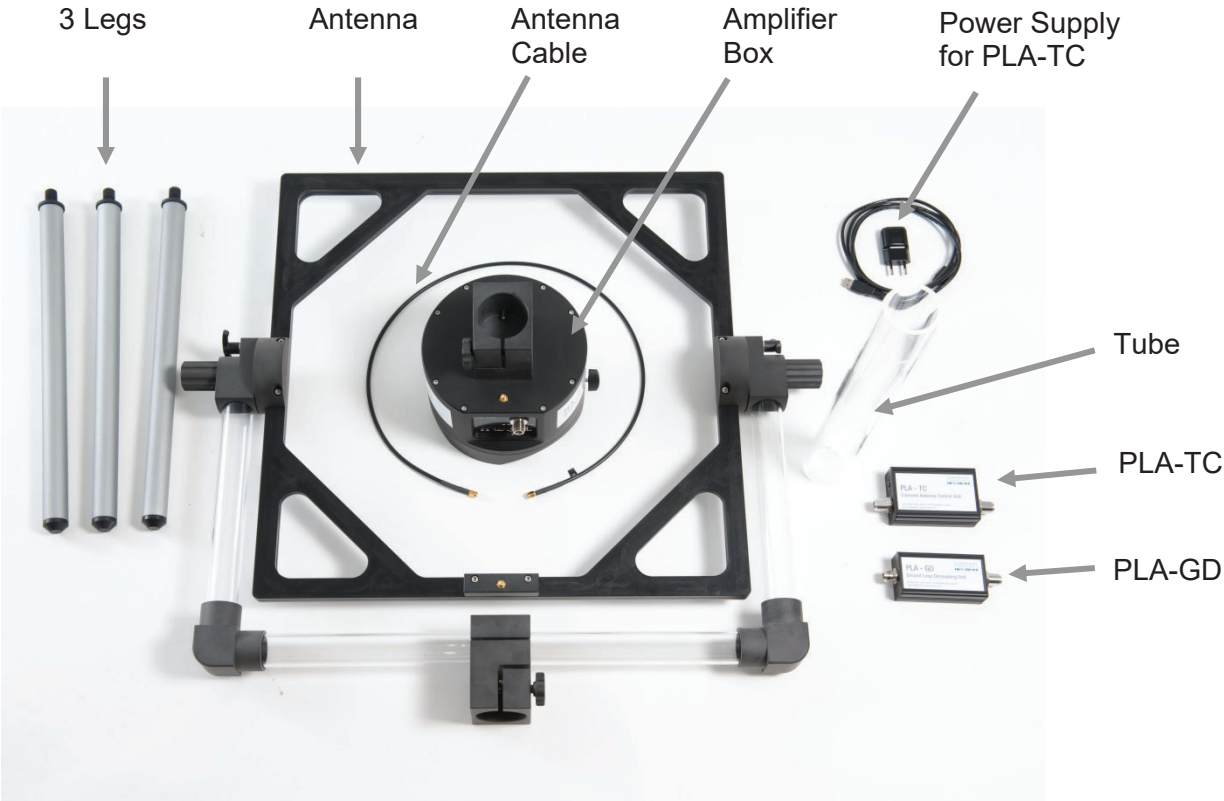


Figure 24: PLA-T components

### 4.3. Assembly of PLA-T and PLA-R

Mount the 3 Legs by turning the Amplifier Box upside down.



Insert the Tube with the milled slot downwards to the fixation of the Base Block.



Fix the Tube with the black screw by hand.



Put the Antenna on the Tube, with the SMA connector of the antenna oriented to the control elements of the amplifier Box.



Fix the Antenna with the black screw by hand.



Connect the Antenna cable (SMA connector) to the antenna. Use a torque wrench to tighten the connector-nut.

The other end of the Antenna cable has to be connected to the Amplifier Box.



## 4.4. Laser alignment system

The PLA antennas can be precisely positioned using the built-in lasers. The dot laser marks the measurement point on the ground and the line laser helps to align the antennas parallel to each other.



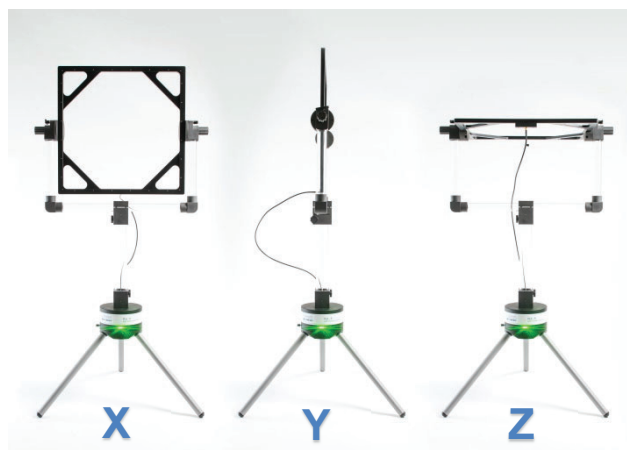
To adjust the line laser release the screw on the Amplifier Box and rotate the case to the target. After the alignment tighten the screw again.



## 4.5. Polarization Change

Polarization Changes of the PLA Antennas can be done very easy and without any tools.

PLA Antenna in X, Y and Z Polarization. →



When the antenna is in X-Polarization, turn the Antenna by 90° according to the milling of the Tube to change to Y-Polarisation.



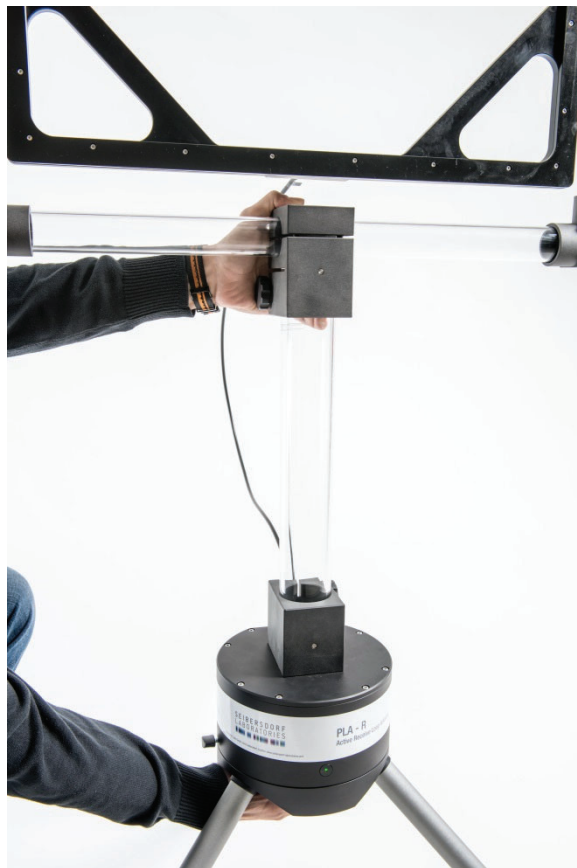
To change to Z- -Polarization, turn the Antenna back to X-Polarisation. Pull out both locking devices and rotate the antenna 90°.



Correct position of Z-axis →



Correct movement of PLA-R/PLA-T →  
Support the Amplifier Box by hand.



Incorrect →

**PLEASE NOTE:**

Damage of the PLA due to incorrect movements is not covered by warranty!



## **4.6. Maintenance**

The PLA-R/PLA-T antennas, including its accessories does not require any user maintenance. Care of the antennas is limited to external components such as cables or connectors.

Clean the exterior of the equipment using a soft cloth and a mild cleaner.

Warranty may be void if the housing is opened.

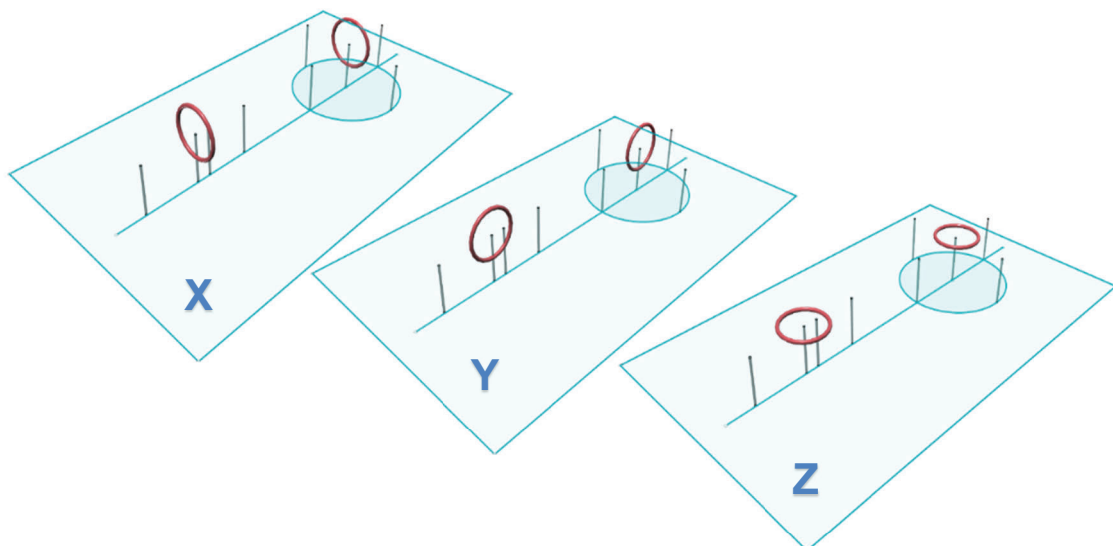
## 5. Applications

### 5.1. Normalized Site Insertion Loss

Methods for the validation of test site for magnetic field disturbance measurements are given by CISPR 16-1-4 [1]. This standard defines the Normalized Site Attenuation (NSA) as well as the Reference Site Method (RSM). Test setup and procedure are identical; difference is only the type of antenna calibration and the resulting post processing. Additional information about magnetic field site validation can be found at [18][19][20].

NSIL validation is desired for the test distances 3 m, 5 m and 10 m. Sites to be tested are Open Area Test Sites (OATS) and semi anechoic chambers (SAC). Magnetic field disturbance measurements are not intended for fully anechoic rooms (FAR).

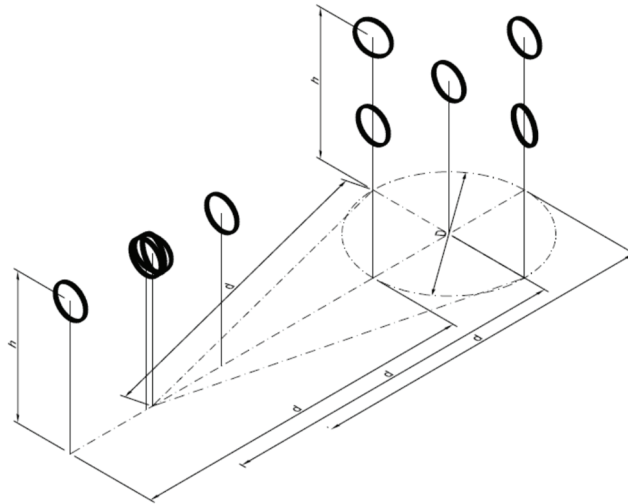
To perform a site validation the pair of loop antennas is set up in three orthogonal orientations, see **Figure 25**. The height of the antenna reference point is 1.3 m above the ground plane. The reference point is defined by the centre of the circular or rectangular loop antenna.



**Figure 25:** Test set up for site validation

These three orientations are required in 5 points inside the test volume, see **Figure 26**. The distance between transmit and receive antenna is kept constant for all measurement points. The antennas are always aligned to each other.

For each test distance the maximum test volume is defined by CISPR 16-2-3 [6].



**Figure 26:** Test points inside test volume; orientation  $H_x$  shown

A site attenuation measurement is performed in two steps. In the first one transmit and receive cable are connected together - the receive level is recorded as  $V_{DIRECT}$ .

In the second step the receive level  $V_{SITE}$  is recorded, when the cables are connected to the antennas.

Depending on test distance and frequency ranges following amplifiers of the PLA-T are recommended.

Test distance	9 kHz – 200 kHz	200 kHz – 30 MHz
3 m	Broadband amplifier	Broadband amplifier
5 m	Broadband amplifier	Broadband amplifier
10 m	High current amplifier	Broadband amplifier

**Table 6:** Recommended amplifier of PLA-T for site validation

- CAUTION:** Do not forget to consider the loss of PLA-TC and PLA-GD during measurement of  $V_{DIRECT}$ .
- CAUTION:** It is not required to install the PLA-TC into the transmit path if only the broadband amplifier of the PLA-T is used.
- CAUTION:** Consider the maximum input power of the PLA-T of -6 dBm.
- CAUTION:** Measuring with network analyser it's recommended to switch off the saturation detection as it's not required and the strong comb signal might damage your network analyser.

In case of the **NSA method** the site attenuation deviation is calculated as follows:

$$\Delta A_S = V_{Direct} - V_{Site} - (F_{a,TX} + F_{a,RX}) - A_N$$

where

- $V_{Direct}$  is the level recorded by the receiver if transmit and receive cable are connected via a barrel connector, in dBm or dB( $\mu$ V);
- $V_{Site}$  is the level recorded by the receiver if transmit and receive cable are connected to the antennas, in dBm or dB( $\mu$ V);
- $F_{a,TX}$  is the transmit magnetic field antenna factor, in dB(S/m);
- $F_{a,RX}$  is the receive magnetic field antenna factor in dB(S/m);
- $A_N$  is the theoretical normalized site attenuation, in dB(m<sup>2</sup>/S<sup>2</sup>), specified in Annex II;
- $\Delta A_S$  is the site attenuation deviation, in dB.

According to CISPR 16-1-4 a site attenuation deviation of  $\pm 4$  dB is allowed.

It is recommended to use the antenna pair method given in CISPR 16-1-4 to calibrate the sum of  $F_{a,TX}$  and  $F_{a,RX}$ . A sample certificate for the PLA-T and PLA-R can be found in Annex IV.

In case of the **RSM method** the site attenuation deviation is calculated as follows:

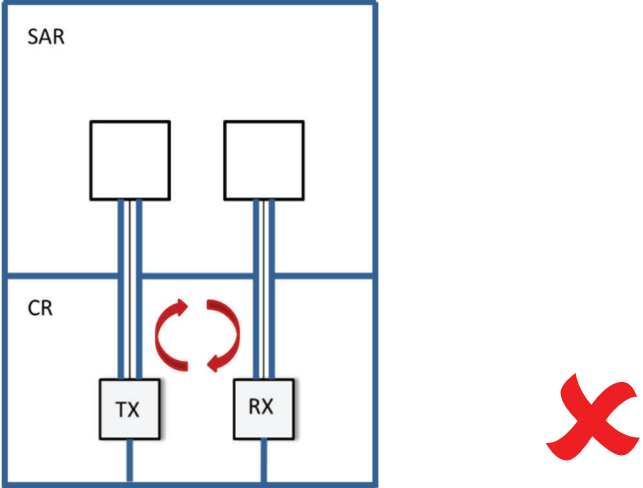
$$\Delta A_S = V_{Direct} - V_{Site} - A_{APR}$$

where

- $V_{Direct}$  is the level recorded by the receiver if transmit and receive cable are connected via a barrel connector, in dBm or dB( $\mu$ V);
- $V_{Site}$  is the level recorded by the receiver if transmit and receive cable are connected to the antennas, in dBm or dB( $\mu$ V);
- $A_{APR}$  is the Antenna Pair Reference, in dB;
- $\Delta A_S$  is the site attenuation deviation, in dB.

At a test distance of 10 m a high dynamic range is required. If the typical setup with measurement devices outside the shielded room is used a ground loop is formed, see **Figure 27**. A current will flow between the chassis of the signal generator, the transmit cable shield, the penetration panel, the receive cable shield, the chassis of the receiver, protective earth to the power outlet and protective earth to the chassis of the signal generator.

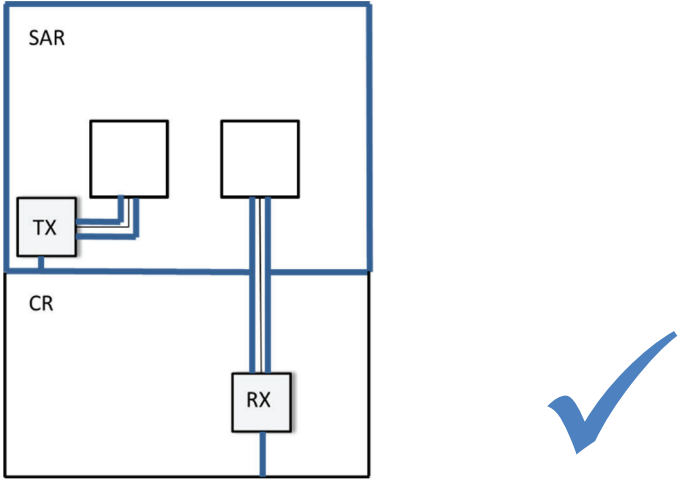
There are several possibilities to avoid a ground loop. Extensive information about ground loops during site validation can be found at [14].



**Figure 27:** Ground loop formed by measurement devices

One possibility to avoid a ground loop is to place the signal generator inside the shielded room. In this case there is no contact between transmit and receive cable shield, see **Figure 28**.

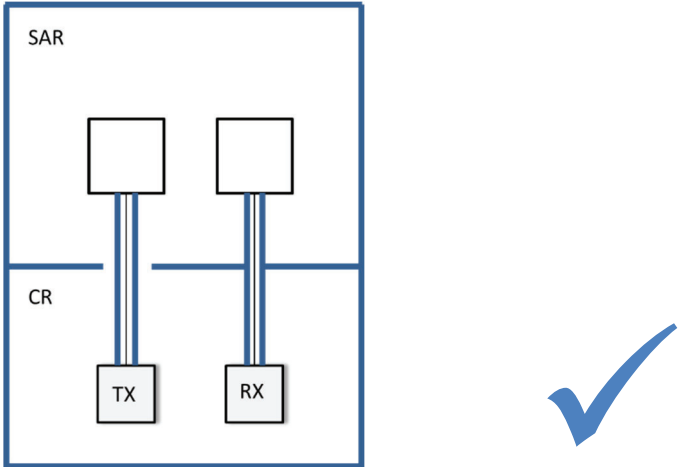
**CAUTION:** Any electric contact between the transmit cable shield and the ground plane will result in a ground loop. Isolate barrel connectors lying on the ground.



**Figure 28:** Operation of generator inside the shielded room

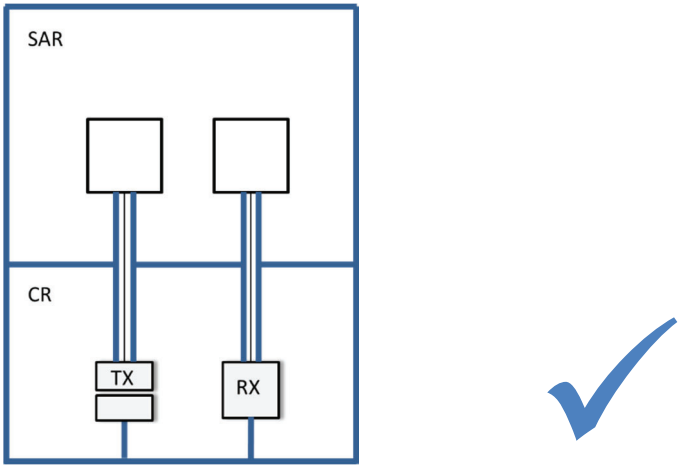
Avoiding an electric contact at the penetration panel will avoid a ground plane, see **Figure 29**.

**CAUTION:** A shielded control room (CR) is required to avoid ambient noise.



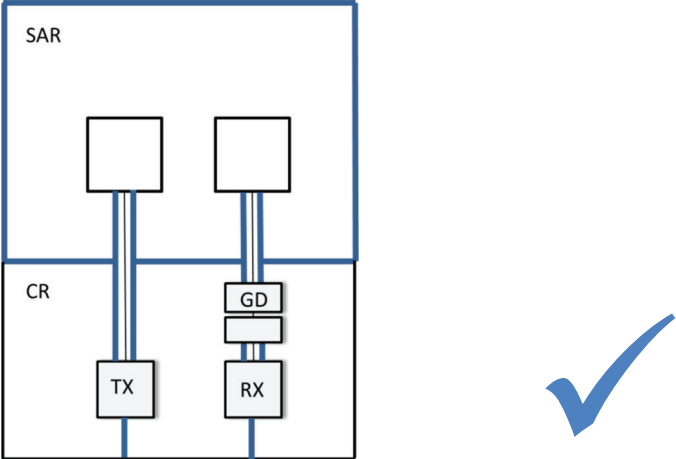
**Figure 29:** Operation of generator and receiver in CR, TX cable not connected to shielding

Some arbitrary waveform generators have an electric isolation between device chassis and signal ground. In this case no ground loop will occur, see **Figure 30**.



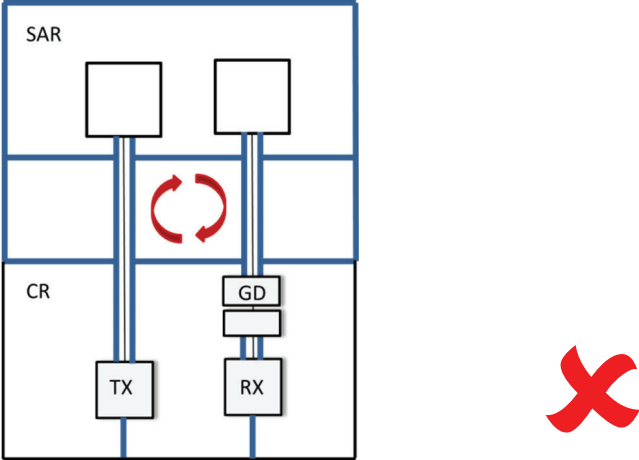
**Figure 30:** Operation of generator with isolation between ground and earth

The recommended possibility to avoid a ground loop is to use the PLA-GD, see **Figure 31**. Due to the isolation between the two ground connections no current flow is possible. A description of the PLA-GD can be found in chapter 2.4, technical information in chapter 3.4.



**Figure 31:** Use of PLA-GD

Typically RF cables are routed between the bottom of the shielding and the raised floor / ground plane, see **Figure 32**. In this case measures against a ground loop outside the shielding will not have an effect. To avoid such secondary ground loops, RF cables should be disconnected from the bulkheads of the floor panel.



**Figure 32:** Ground loop with fixed installed cables beneath ground plane

## 5.2. Shielding Effectiveness

The PLA set can be used for shielding effectiveness measurements according to

- EN 50147-1 [9]
- IEEE Std. 299 [1]
- NSA No. 94-106 [17]

Following standards cannot be used

- MIL-STD 285 **Fehler! Verweisquelle konnte nicht gefunden werden.**] - Different requirement for loop size

The shielding effectiveness measurement according EN 50147-1 is measured by two steps. The first step is to measure  $H_0$  in the reference configuration, see **Figure 33(a)**. Therefore both antennas are placed parallel to each other at a distance  $d_0$ , where

$$d_0 = d_1 + d_2 + d_3$$

Typically  $d_1$  and  $d_2$  are 30 cm,  $d_3$  is the thickness of the shielded wall.

After this normalization, the receive antenna is setup inside the shielded enclosure and the transmit antenna outside.

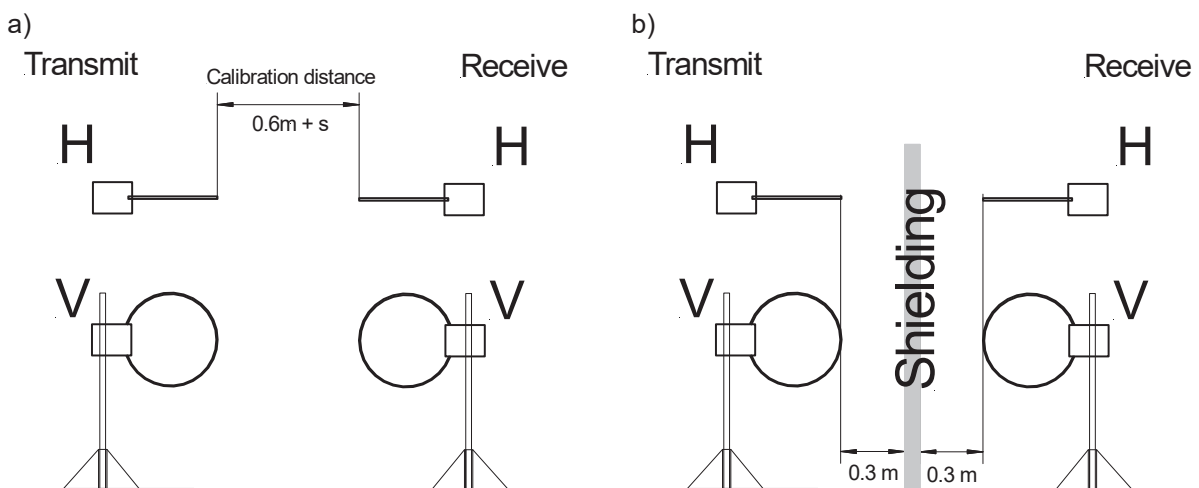
The magnetic field  $H_1$  is measured and the shielding effectiveness is calculated by

$$A = 20 \log \left( \frac{H_0}{H_1} \right)$$

Since the antenna factor of the receive loop is equal for both measurement the formula is simplified to

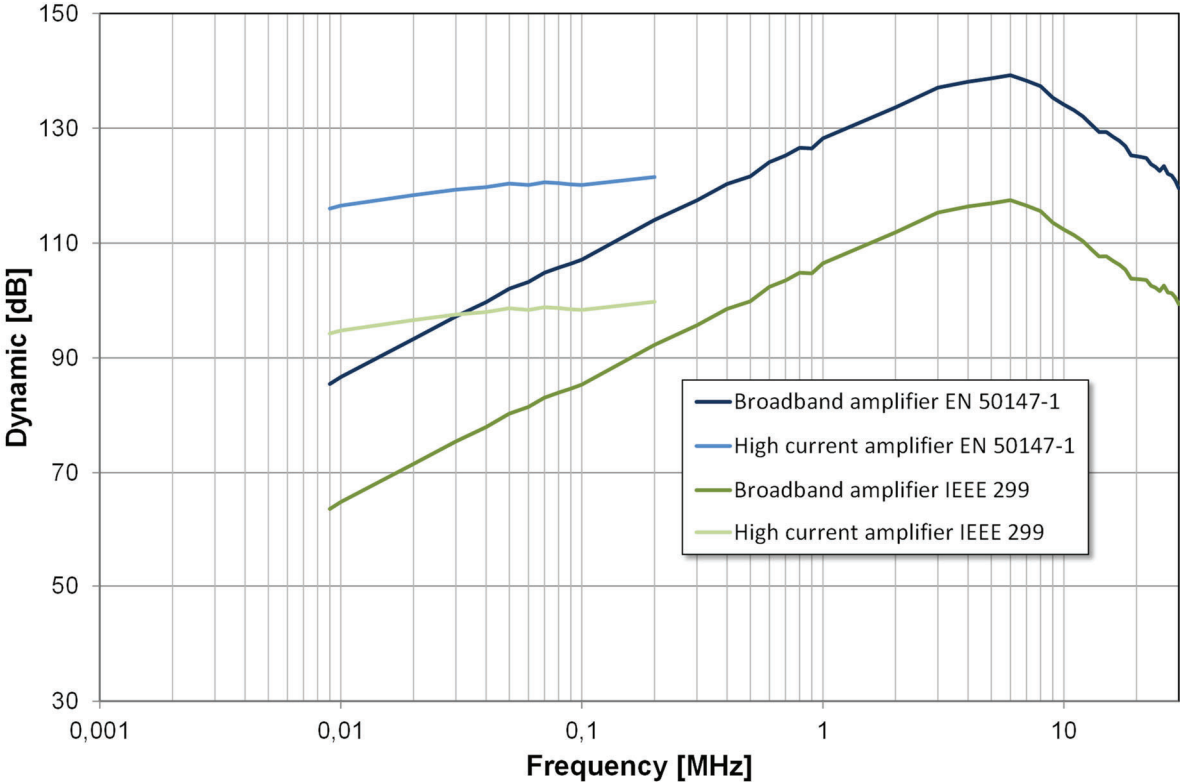
$$A = 20 \log \left( \frac{V_0}{V_1} \right)$$

Shielding effectiveness measurements according to other standards are performed using the same principle. Differences are the required antenna orientations and distances as well as limits.



**Figure 33:** Shielding effectiveness measurement setup  
a) calibration; the calibration distance should include the thickness of the shielding  
b) measurement

The typical dynamic range for shielding effectiveness measurements using the PLA set is given in **Figure 34**.



**Figure 34:** Dynamic range; 10 Hz resolution bandwidth

### 5.3. Radiated Disturbance

The PLA-R antenna can be used for radiated disturbance measurements according to

- ANSI C63.4 [1]
- CISPR 11 [2]
- CISPR 14 [3]
- CISR 16-2-3 [6]
- CISPR 36 [7]
- EN 302 291-1 [8]
- ETSI TR 103 409 [10]
- CISPR 32 [11]
- ITU-R SM.2303-4 [13]

Following standard cannot be used

- MIL-STD-461G [16] and preceding - Different requirement for loop size and number of turns

Radiated disturbance measurements are performed by using the magnetic field antenna factor. To calculate the magnetic field also the cable loss between antenna and receiver has to be considered

$$H[dB\mu A/m] = U_{receiver}[dB\mu V] + F_A[dBS/m] + A_{cable}[dB]$$

#### CAUTION:

Do not mix up the magnetic field antenna factor [dBS/m] with the antenna factor [dB/m]. Some standard require magnetic field measurements and define an electric field limit. In this case a wave impedance of 377  $\Omega$  is assumed.

Typically an EMI receiver according to CISPR 16-1-1 [4] is used for compliant radiated disturbance measurements. This standard described the function of the quasi-peak detector and the requirements regarding dynamic range which are fulfilled by using a preselector. Using a preamplifier between antenna and EMI receiver may cause some troubles; see Annex K of CISPR 16-1-6. The same is true for active antennas. Saturation and intermodulation can invalidate the test results especial for pulsed signals. More information about measuring pulsed magnetic fields can be found at [15].

To avoid those problems the PLA-R is equipped with a saturation indication feature. The saturation detection is sensitive to single pulses also. After a saturation event the indication remains on for at least 3 seconds.

A human observation of the saturation indication LED is not necessary due to the patented overload handover. In case of saturation of the antenna a strong wideband signal is generated and routed to the antenna output. This signal is strong enough to force the EMI receiver into overload, which is also recognized by the automated EMC control software.

To ensure proper function suitable settings on the EMI receiver must be found. If a high input attenuation is set, the pulsed signal will not affect an overload.

#### CAUTION:

Before using the saturation indication feature, the operator has to check if the EMI receiver with the current settings will show an overload due to the pulsed signal. Failure to do so will result in erroneous measurement results.

Typical values to the most common EMI receivers are given in **Table 7** to **Table 9**.

	Frequency	Max. Attenuation
CISPR Band A	9 kHz – 150 kHz	30 dB
CISPR Band B	150 kHz – 30 MHz	25 dB

**Table 7:** Typical settings for Rhode & Schwarz ESIB

	Frequency	Max. Attenuation
CISPR Band A	9 kHz – 150 kHz	25 dB
CISPR Band B	150 kHz – 30 MHz	40 dB

**Table 8:** Typical settings for Rhode & Schwarz ESW

	Frequency	Max. Attenuation
CISPR Band A	9 kHz – 150 kHz	16 dB
CISPR Band B	150 kHz – 30 MHz	24 dB

**Table 9:** Typical settings for Keysight MXE N9038A

If the used EMI receiver is not listed following procedure to find maximum attenuation should be used:

1. Tune receiver to frequency of CISPR Band A where no harmonic is inside the resolution bandwidth e.g. 25 kHz
2. Set attenuator to 10 dB
3. Turn on pulse generator with test switch, see **Figure 2**.
4. Increase attenuation until no overload is shown by the receiver.
5. Switch back one attenuator step and note maximum attenuation
6. Repeat step 1 to 5 with frequency of Band B. Due to preselector design testing at several frequencies may be required.

The operator has to decide if the PLA-R antenna is used in active or passive mode. This decision has to be made according the minimum / maximum field strength, see **Figure 13** and **Figure 14**, and the applicable limit.

**CAUTION:** Do not forget to assign the correct antenna factor to your EMI measurement software when changing the operation mode of the PLA-R.

Typically for measurements at 3 m distance the noise floor when using the PLA-R in passive mode is sufficient. When the equipment under test (EUT) shows strong pulsed signals, the use of the passive mode is also recommended.

## 6. Calibration

Regarding the proper calibration of the loop antennas in the CISPR world we must distinguish two use-cases:

- **measuring the radiated emissions**
- **validating the test site** (2 approaches).

This explanation should guide you through the CISPR Jungle and considering Annex N you should be able to make or request from your calibration laboratory the best possible calibration!

### 6.1. Calibration of the individual antenna factor

The calibration of the **individual antenna factor** is required for the receive antenna (RX) for radiated disturbance measurements as per CISPR 16-2-3 for example.

The methods are described in CISPR 16-1-6 (CISPR 16-1-6:2014+AMD1:2017+AMD2:2022 CSV 2022-03-03)

Chapter 5.2 describes the 4 procedures for the calibration of the Antenna Factor of loop antennas in the frequency range 9 kHz to 30 MHz:

5.2.2 TEM (Crawford) cell method

5.2.3 Three antenna method (TAM)

5.2.4 Current probe method (CPM)

5.2.5 Standard antenna method

The method of choice is the TEM (Crawford) cell method that we have implemented in Seibersdorf already long before the standard was available. It's very precise and sensitive but you need a very large TEM cell.



**Figure 35:** Large TEM cell for calibration of 60cm loop antennas

## 6.2. Calibration of the antenna pair

The calibration of the **antenna pair** (T + R) is required for site validation according to CISPR 16-1-4 and described in CISPR 16-1-4/AMD2 (latest consolidated edition: CISPR 16-1-4:2019+AMD1:2020+AMD2:2023 CSV, 2023-04-13) Annex N.

In Chapter 4.3.2 Magnetic field antenna there is a requirement that “The magnetic field antenna shall be calibrated according to CISPR 16-1-6 for determination of the magnetic field antenna factor.”

Where in Chapter 5.5.2 Normalized site insertion loss (NSIL) the magnetic antenna factors ( $F_{aH,T}$  and  $F_{aH,R}$ ) are required in Formula 27:

$$\Delta A_i = V_{DIRECT} - V_{SITE} - F_{aH,T} - F_{aH,R} - A_{Ni}$$

The calculated NSIL table providing  $A_{Ni}$  for different loop antenna dimensions and shapes including PLA antenna can be found at the link in Annex J.5:

[https://www.iec.ch/dyn/www/f?p=103:227:15032641706403:::FSP\\_ORG\\_ID,FSP\\_LANG\\_ID:1327,25](https://www.iec.ch/dyn/www/f?p=103:227:15032641706403:::FSP_ORG_ID,FSP_LANG_ID:1327,25)

Also, in the PLA manual in ANNEX V. “NSA values for site validation” you find the NEC code to compute the values for the PLA yourself.

Now there comes the **important Annex N** (normative) of CISPR 16-1-4: Calibration of the sum of antenna factors in the frequency range of 9 kHz to 30 MHz

One can rewrite Formula 27 to:

$$\Delta A_i = V_{DIRECT} - V_{SITE} - (F_{aH,T} + F_{aH,R}) - A_{Ni}$$

Where **only the sum of the T and R antenna factors** is required. This permits use of a modified antenna calibration method, rather than the methods of CISPR 16-1-6. Calibrating both loop antennas as a pair has the advantage of **potentially reducing the measurement uncertainty** of the site validation measurement results.

Annex N.2 describes the calibration procedure that requires only one SIL measurement between the two antennas with a network analyzer. The distance between the antennas shall be between 0,3 m and 1 m. It is easy to maintain a sufficient signal to noise ratio in this distance range, and the influence of nearby objects is small:

$$F_{aH,T} + F_{aH,R} = A_i - A_{Ni}$$

$$A_i = -20\lg S_{21} \text{ in dB}$$

$A_{Ni}$  is the normalized site insertion loss in dB(m2/S2) **for the calibration geometry!!!** (e.g. 30 cm distance). Please use the NEC code in the PLA manual in ANNEX V. to compute the  $A_{Ni}$  for the calibration.

### 6.3. Calibration of the antenna pair reference

**The antenna pair reference is calibrated** for the validation according to CISPR 16-1-4 **reference site method**

As alternative procedure for test site validation in the range 9 kHz – 30 MHz there is **the Reference site method** in Chapter 5.5.3 of CISPR 16-1-4.

According to Formula 29:

$$\Delta A_i = V_{DIRECT} - V_{SITE} - A_{LPR}$$

No calibration of the antenna factor is required, but the antenna pair reference  $A_{LPR}$  is calibrated at a REFTS Site. The site needs sufficient quality, but no theoretical or numerically computed values are required.

## 7. Literature and information

- [1] ANSI C63.4, "American National Standard for Methods of Measurement of Radio-Noise Emissions from Low-Voltage Electrical and Electronic Equipment in the Range of 9 kHz to 40 GHz", IEEE, 2014
- [2] CISPR 11, "Industrial, scientific and medical equipment – Radio-frequency disturbance characteristics – Limits and methods of measurement", Edition 7.0, 2024-02
- [3] CISPR 14, "Electromagnetic compatibility – Requirements for household appliances, electric tools and similar apparatus – Part 1: Emission", Edition 7.0, 2020-09
- [4] CISPR 16-1-1, "Specification for radio disturbance and immunity measuring apparatus and methods – Part 1-1: Radio disturbance and immunity measuring apparatus – Measuring apparatus", Edition 5.0, 2019-05
- [5] CISPR 16-1-4, "Specification for radio disturbance and immunity measuring apparatus and methods – Part 1-4: Radio disturbance and immunity measuring apparatus – Antennas and test sites for radiated disturbance measurements", Edition 4.2, 2023-04
- [6] CISPR 16-2-3, "Specification for radio disturbance and immunity measuring apparatus and methods – Part 2-3: Methods of measurement of disturbances and immunity – Radiated disturbance measurements", Edition 4.2, 2023-06
- [7] CISPR 36, "Electric and hybrid electric road vehicles - Radio disturbance characteristics - Limits and methods of measurement for the protection of off-board receivers below 30 MHz", Edition 1.0, 2023-05
- [8] EN 302 291-1, "Electromagnetic compatibility and Radio spectrum Matters (ERM); Short Range Devices (SRD); Close Range Inductive Data Communication equipment operating at 13,56 MHz; Part 1: Technical characteristics and test methods", 2005-07
- [9] EN 50147-1, "Anechoic chambers - Part 1: Shield attenuation measurement", March 1996
- [10] ETSI TR 103 409, "System Reference document (SRdoc); Wireless Power Transmission (WPT) systems for Electric Vehicles (EV) operating in the frequency band 79 - 90 kHz", V1.1.1, 2016-10
- [11] CISPR 32, "Electromagnetic compatibility of multimedia equipment - Emission requirements, Edition 2.0, 2019-10
- [12] IEEE Std. 299-2006, "IEEE Recommended practice for Measurement of Shielding Effectiveness of High-Performance Shielding Enclosures", 28 February 2007
- [13] ITU-R SM.2303-4, "Wireless power transmission using technologies other than radio frequency beam", 06/2023
- [14] A. Kriz, „Ground loops during site validation of anechoic rooms below 30 MHz”, IEEE Symposium on Electromagnetic Compatibility, Signal and Power Integrity, Long Beach, California, USA 2018
- [15] A. Kriz, „Saturation of Active Loop Antennas”, IEEE Symposium on Electromagnetic Compatibility, Signal and Power Integrity, Ottawa, Canada 2016
- [16] MIL-STD-461G, "DEPARTMENT OF DEFENSE INTERFACE STANDARD REQUIREMENTS FOR THE CONTROL OF ELECTROMAGNETIC INTERFERENCE CHARACTERISTICS OF SUBSYSTEMS AND EQUIPMENT", 11 December 2015
- [17] NSA No. 94-106, "National Security Agency Specification for Shielded Enclosures", 24 October 1994
- [18] F. W. Trautnitz, J. Riedelsheimer, „Erstellung eines Validierungsverfahrens für EMV Messplätze im Frequenzbereich von 9 kHz bis 30 MHz mit Magnetfeldantennen“, EMV Düsseldorf, 2014

- [19] F. W. Trautnitz, J. Riedelsheimer, „Validierung von Feldstärke - Messplätzen im Frequenzbereich von 9 kHz – 30 MHz mit Rahmen-Antennen“, EMV Düsseldorf, 2016
- [20] F. W. Trautnitz, A. Kriz, A. Morgenstern, J. Riedelsheimer, R. Svadlenka „Eignung von Messplätzen im Frequenzbereich von 9 kHz bis 30 MHz mit Rahmenantennen“, EMV Düsseldorf, 2018

## ANNEX I. WARRANTY

Seibersdorf Labor GmbH, hereinafter referred to as the Seller, warrants that standard Seibersdorf Laboratories products are free from defect in materials and workmanship for a period of two (2) years from the date of shipment.

### **Standard Seibersdorf Laboratories products include the following:**

- Antennas
- Cables
- Reference Radiators
- Software
- Antenna stands and positioners

If the Buyer notifies the Seller of a defect within the warranty period, the Seller will, at the Seller's option, either repair and/or replace products which prove to be defective during the warranty period.

There will be no charge for warranty services performed at the location the Seller designates. The Buyer must, however, prepay inbound shipping costs and any duties or taxes. The Seller will pay outbound shipping cost for a carrier of the Seller's choice, exclusive of any duties or taxes.

### **This warranty does not apply to:**

- Normal wear and tear of materials
- Consumable items such as fuses, batteries, etc.
- Products that have been improperly installed, maintained or used
- Products which have been operated outside the specifications
- Products which have been modified without authorization
- Calibration of products, unless necessitated by defects

**THIS WARRANTY IS EXCLUSIVE.** NO OTHER WARRANTY, WRITTEN OR ORAL, IS EXPRESSED OR IMPLIED, INCLUDING BUT NOT LIMITED TO, THE IMPLIED WARRANTIES OF MERCHANTABILITY AND FITNESS FOR A PARTICULAR PURPOSE. THE REMEDIES PROVIDED BY THIS WARRANTY ARE THE BUYER'S SOLE AND EXCLUSIVE REMEDIES. IN NO EVENT IS THE SELLER LIABLE FOR ANY DAMAGES WHATSOEVER, INCLUDING BUT NOT LIMITED TO, DIRECT, INDIRECT, SPECIAL, INCIDENTAL, OR CONSEQUENTIAL DAMAGES, WHETHER BASED ON CONTRACT, TORT, OR ANY OTHER LEGAL THEORY.

## ANNEX II. Safety against electromagnetic fields

The PLA-T transmit antenna radiated a strong magnetic field when high current amplifier is used. Therefore information about Electromagnetic Fields (EMF) is given. This information can be used to state compliance with Directive 2013/35/EU - on the minimum health and safety requirements regarding the exposure of workers to the risks arising from physical agents (electromagnetic fields).

### EMF data sheet:

Issued by                    Seibersdorf Labor GmbH  
Valid from                 2018-08-01

### Equipment information:

Brand name                Seibersdorf Laboratories  
Model name                PLA-T  
  
Intended use                occupational

### Basic information:

Applied regulation        none  
Referenced limits        Directive 2013/35/EU, Recommendation 1999/519/EC  
Applied standard         IEC 62226-3-1

Non-Thermal effects need to be considered for workplace assessment        yes  
Thermal effects need to be considered for workplace assessment            yes

Data is based on maximum power source capability

### EMF data for non-thermal effects:

	Head		Trunk	Limb hand
	Sensory effects	Health effects		
Required minimum distance	1 cm	1 cm	1 cm	0 cm

**Table II.1:** EMF data for non-thermal effects

### EMF data for thermal health effects:

	Head	Trunk	Limb hand
Required minimum distance	1 cm	1 cm	0 cm

**Table II.2:** EMF data for thermal health effects

Distance where compliance with general public limits is reached: 25 cm

## ANNEX III. Laser Safety

As described in chapter 2 the PLA-TX and PLA-RX has a dot-laser and a line laser. The lasers are shown in **Figure 36**.



**Figure 36:** Lasers

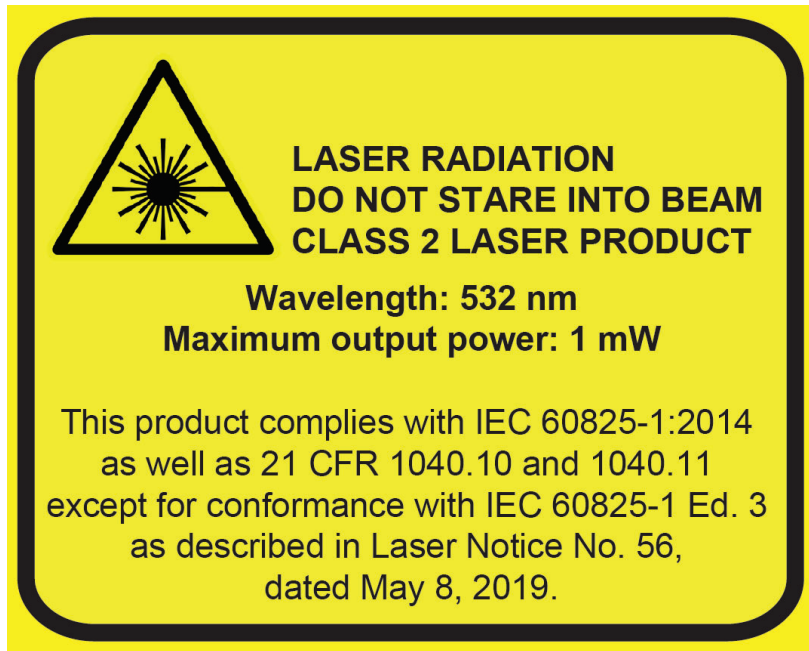
The product is classified as Class 2 laser product according to IEC 60825-1:2014 as well as EN 60825-1:2014+AC:2017+A11:2021+A11:2021/AC:2022. It furthermore complies with 21 CFR 1040.10 and 1040.11 except for conformance with IEC 60825-1 Ed. 3., as described in Laser Notice No. 56, dated May 8, 2019.

The specifications of the laser are found in **Table 10**.

	dot-laser	line-laser
Wavelength	532 nm	532 nm
Maximum output	1 mW CW	1 mW CW
Divergence	0,5 mrad	0,5 mrad
Fan angle	-	90°

**Table 10:** Laser Specification

On the bottom of the “antenna box” warning labels are placed near the dot-laser, see **Figure 37**.



**Figure 37:** Warning labels

## ANNEX IV. Battery Information

The amplifier box of PLA-R and PLA-T include a 10-cell Nickel-Metal hydride battery pack each.

A sealed Nickel-Metal hydride cell/battery is not hazardous in normal use; especially the release of hydrogen gas is excluded.

In case of mistreatment (abusive over charge, reverse charge, external short circuit...) and in case of fault some electrolyte can leak from the cell through the safety device. In these cases refer to the risk of potassium hydroxide solution (corrosive, pH > 14). The electrode materials are only hazardous, if the materials are released by mechanical damaging of the cell or if exposed to fire.

Storage is preferred at room temperature 20°C. Avoid large temperature changes. Do not store close to the heating. Avoid direct sunlight.

In the European Union, manufacturing, handling and disposal of batteries is regulated on the basis of the REGULATION (EU) 2023/1542 OF THE EUROPEAN PARLIAMENT AND OF THE COUNCIL of 12 July 2023 concerning batteries and waste batteries, amending Directive 2008/98/EC and Regulation (EU) 2019/1020 and repealing Directive 2006/66/EC. Customers find detailed information on disposal in their specific countries using the web site of the European Portable Batteries Association (<https://www.epbaeurope.net/>).

Users outside EU should consider the local law and rules.

Nickel-Metal hydride Batteries (also referred as "Dry cells") are not defined as dangerous goods under IATA Dangerous Goods Regulations (DGR) 66<sup>th</sup> edition 2025. This kind of batteries are not subject to the IATA-DGR as they are compliant with the special provision requirements. In addition, the IATA-DGR require the words "not restricted" and Special Provision number A199 on the air waybill, when air waybill is issued.

For maritime transport the Nickel-Metal hydride batteries are regulated by IMDG (Inter-national Maritime Dangerous Goods) under UN3496 BATTERIES, NICKEL METAL HYDRIDE, CLASS 9 with Special Provision 117 and 963. They are not subject to other provisions of this Code if less than 100 Kg total gross weight is loaded in a cargo transport unit.

Nickel-Metal hydride Batteries are no subject of the Dangerous Goods Regulations ADR/RID for Transports on Road or Rail.

## ANNEX V. NSA values for site validation

The NSA values are given in **Figure 39** and are available as Excel File for download (<https://rf.seibersdorf-laboratories.at/products-services/antennas/pla-set>). **Table 11** to **Table 13** shows a few values of the tables.

According to CISPR 16-1-4 additional information together with the NSA values should be supplied to maintain traceability.

This information should contain:

Description of feed points, see **Figure 38**

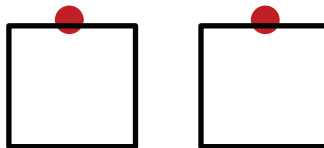
NEC source code, see **Table 14**

used NEC core: 4NEC2, Version V5.7.4, Arie Voors, [HTTP://WWW.QSL.NET/4NEC2](http://www.qls.net/4NEC2)

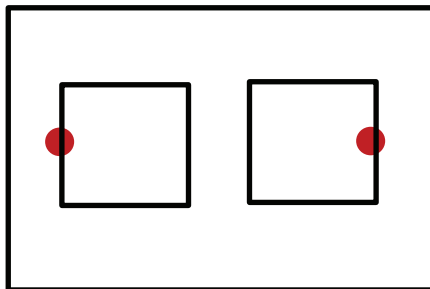
a)  $H_x$  front view



b)  $H_y$  front view

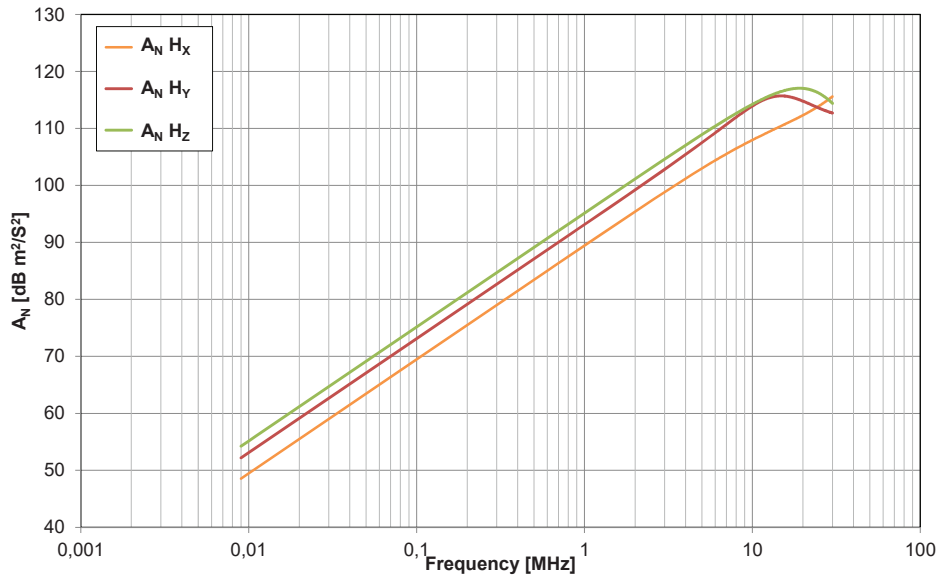


c)  $H_z$  top view

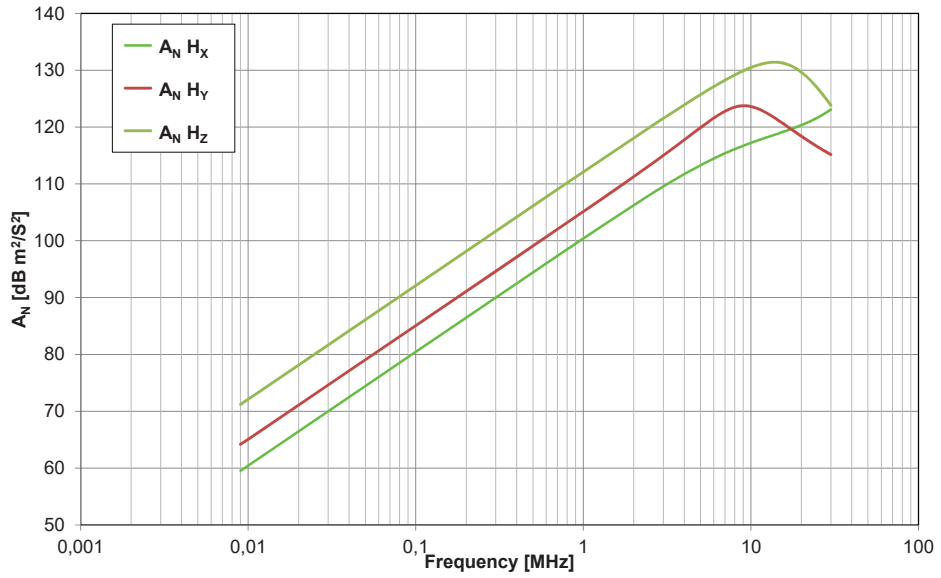


**Figure 38:** Specification of the feed points

a)



b)



c)

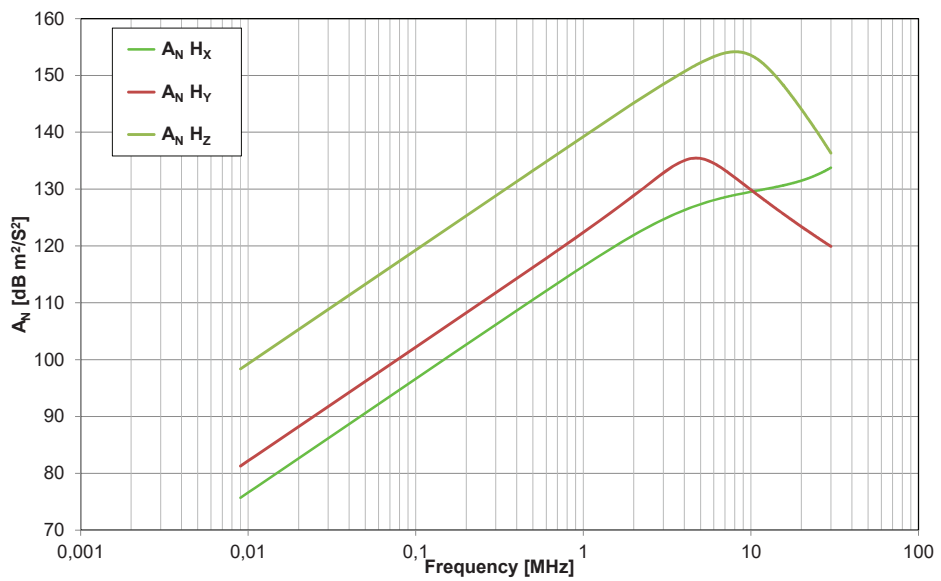


Figure 39: NSA values a) 3 m b) 5 m c) 10 m

**Table 11:** NSA values, 3 m

Frequency MHz	F <sub>aH</sub> dB S/m	SIL H <sub>x</sub> dB	SIL H <sub>y</sub> dB	SIL H <sub>z</sub> dB	A <sub>N</sub> H <sub>x</sub> dB m <sup>2</sup> /S <sup>2</sup>	A <sub>N</sub> H <sub>y</sub> dB m <sup>2</sup> /S <sup>2</sup>	A <sub>N</sub> H <sub>z</sub> dB m <sup>2</sup> /S <sup>2</sup>
0,009	31.91	112.36	116.01	118.04	48.54	52.19	54.23
0,01	30.99	111.45	115.09	117.13	49.46	53.11	55.14
....							
29,9	-18.44	78.68	75.83	77.54	115.56	112.71	114.43
30	-18.44	78.71	75.82	77.50	115.60	112.70	114.39

**Table 12:** NSA values, 5 m

Frequency MHz	F <sub>aH</sub> dB S/m	SIL H <sub>x</sub> dB	SIL H <sub>y</sub> dB	SIL H <sub>z</sub> dB	A <sub>N</sub> H <sub>x</sub> dB m <sup>2</sup> /S <sup>2</sup>	A <sub>N</sub> H <sub>y</sub> dB m <sup>2</sup> /S <sup>2</sup>	A <sub>N</sub> H <sub>z</sub> dB m <sup>2</sup> /S <sup>2</sup>
0.009	31.91	123.36	127.98	135.03	59.54	64.17	71.21
0.01	30.99	122.44	127.07	134.11	60.46	65.08	72.13
...							
29.9	-18.44	86.17	78.31	87.00	123.05	115.19	123.88
30	-18.44	86.19	78.28	86.94	123.08	115.17	123.83

**Table 13:** NSA values, 10 m

Frequency MHz	F <sub>aH</sub> dB S/m	SIL H <sub>x</sub> dB	SIL H <sub>y</sub> dB	SIL H <sub>z</sub> dB	A <sub>N</sub> H <sub>x</sub> dB m <sup>2</sup> /S <sup>2</sup>	A <sub>N</sub> H <sub>y</sub> dB m <sup>2</sup> /S <sup>2</sup>	A <sub>N</sub> H <sub>z</sub> dB m <sup>2</sup> /S <sup>2</sup>
0.009	31.91	139.53	145.10	162.18	75.72	81.29	98.37
0.01	30.99	138.62	144.19	161.27	76.63	82.20	99.28
...							
29.9	-18.44	96.86	83.06	99.53	133.74	119.94	136.42
30	-18.44	96.88	83.03	99.46	133.76	119.92	136.35

**Table 14:** NEC source code

CM SEIBERSDORF LABORATORIES  
CM SIMULATION OF SIL  
CM PRECISION LOOP ANTENNA PLA  
CM 2018  
CM  
CE  
GW 1 9 0.300 -0.300 0 -0.300 -0.300 0 0.001  
GW 2 9 0.300 0.300 0 -0.300 0.300 0 0.001  
GW 3 9 0.300 -0.300 0 0.300 0.300 0 0.001  
GW 4 9 -0.300 0.300 0 -0.300 -0.300 0 0.001  
GW 5 9 0.300 -0.300 0 -0.300 -0.300 0 0.001  
GW 6 9 0.300 0.300 0 -0.300 0.300 0 0.001  
GW 7 9 0.300 -0.300 0 0.300 0.300 0 0.001  
GW 8 9 -0.300 0.300 0 -0.300 -0.300 0 0.001  
GM 0 0 90 180 0 0 0 1.300 0  
GM 0 0 0 0 0 0 3.000 0 5  
GE 1  
GN 1  
EK  
EX 0 1 5 0 0 2 0  
LD 0 1 5 5 50 0 0  
LD 0 5 5 5 50 0 0  
FR 0 1 0 0 30.000 1  
PT 0 5 5 5  
XQ

# ANNEX VI. Sample Certificate of Antenna Calibration

A sample calibration certificate for the PLA-R is given on the following pages.

Kalibrierstelle für Antennen und Feldsonden  
*Calibration Body for Antennas and Field Probes*

Akkreditiert durch / *accredited by*  
**AKKREDITIERUNG AUSTRIA**



Kalibrierschein nach ISO/IEC 17025  
*Calibration Certificate according to ISO/IEC 17025*

Kalibrierzeichen  
*Calibration mark*

EH-XXXX/XX
<b>0612</b>

Gegenstand  
*Object*                      Active Loop Antenna

Hersteller & Typ  
*Manufacturer & Type*                      Seibersdorf Labor GmbH PLA-R

Herstellernummer  
*Serial number*

Auftraggeber  
*Customer*

Auftragsnummer  
*Order Nr.*

Anzahl der Seiten des Kalibrierscheines    1 - 3  
*Number of pages of the certificate*

Datum und Ort der Kalibrierung  
*Date and place of calibration*

Akkreditierung Austria ist Vollmitglied bei der International Laboratory Accreditation Cooperation ILAC und Unterzeichner der MRAs für die Bereiche „Testing, Calibration and Inspection“.

Die Kalibrierung erfolgt auf der gesetzlichen Grundlage des Akkreditierungsgesetzes in gültiger Fassung entsprechend den Anforderungen der ÖVE/ÖNORM EN ISO/IEC 17025.

Dieser Kalibrierschein dokumentiert die Rückführbarkeit auf nationale Normale zur Darstellung der physikalischen Einheiten in Übereinstimmung mit dem Internationalen Einheitensystem (SI).

Für die Einhaltung einer angemessenen Frist zur Wiederholung der Kalibrierung ist der Benutzer verantwortlich.

*Akkreditierung Austria is a full member of the International Laboratory Accreditation Cooperation ILAC and a signatory of the MRA for "Testing, Calibration and Inspection".*

*The calibration is performed in accordance with the Akkreditierungsgesetz in the amended version and the requirements of ÖVE/ÖNORM EN ISO/IEC 17025.*

*This calibration certificate documents the traceability to national standards, which realize the physical units or measurements according to the International System of Units (SI).*

*The user is obliged to have the object recalibrated at appropriate intervals.*

Dieser Kalibrierschein gilt ausschließlich für den kalibrierten Gegenstand und darf nur vollständig und unverändert weiterverarbeitet werden. Auszüge oder Änderungen sind unzulässig. Kalibrierscheine ohne Unterschrift haben keine Gültigkeit.

*This calibration certificate is valid only for the calibrated object and may not be reproduced other than in full. Calibration certificates without signature are not valid.*

Datum  
*Date*

Zeichnungsberechtigter  
*Authorized person*

Bearbeiter  
*Person responsible*

## Calibration Procedure

Calibration of the **antenna factor** is carried out according to the TEM-Cell Method described in internal process guideline LE-EH-VA-A01 (2023-12). The calibration fulfils the requirements given in CISPR 16-1-6.

$H \text{ [dB}\mu\text{A/m]} = V \text{ [dB}\mu\text{V]} + F_{\text{aH}} \text{ [dB}/\Omega\text{m]}$	$F_{\text{aH}}$ Magnetic field antenna factor
	H Magnetic field strength
	V Voltage at terminals of loop antenna

## Test Equipment

Type	Identification
Network Analyzer Keysight E5061B	E0192
TEM Cell - Large	E1021
CalStan 11	E0921

## Environmental Conditions

Site Temperature	20°C - 27°C
Site Humidity	30% - 80%
Control Temperature	20°C - 27°C
Control Humidity	30% - 80%

## Results

Type	Description	Fig./Table
Antenna Factor H	9kHz-30MHz	1

## Accuracy of Calibration

The reported expanded uncertainty of measurement is stated as the standard uncertainty of measurement multiplied by the coverage factor  $k = 2$ , which for a normal distribution corresponds to a coverage probability of approximately 95%. The standard uncertainty of measurement has been determined in accordance with EAL Publication EA 4/02.

## References

- [1] CISPR 16-1-6:2014+AMD1:2017+AMD2:2022 CSV, Specification for radio disturbance and immunity measuring apparatus and methods - Part 1-6: Radio disturbance and immunity measuring apparatus - EMC antenna calibration
- [2] EA-4/02 M: 2022 Evaluation of the Uncertainty of Measurement in calibration

Figure 1: Antenna Factor H; 9kHz-30MHz

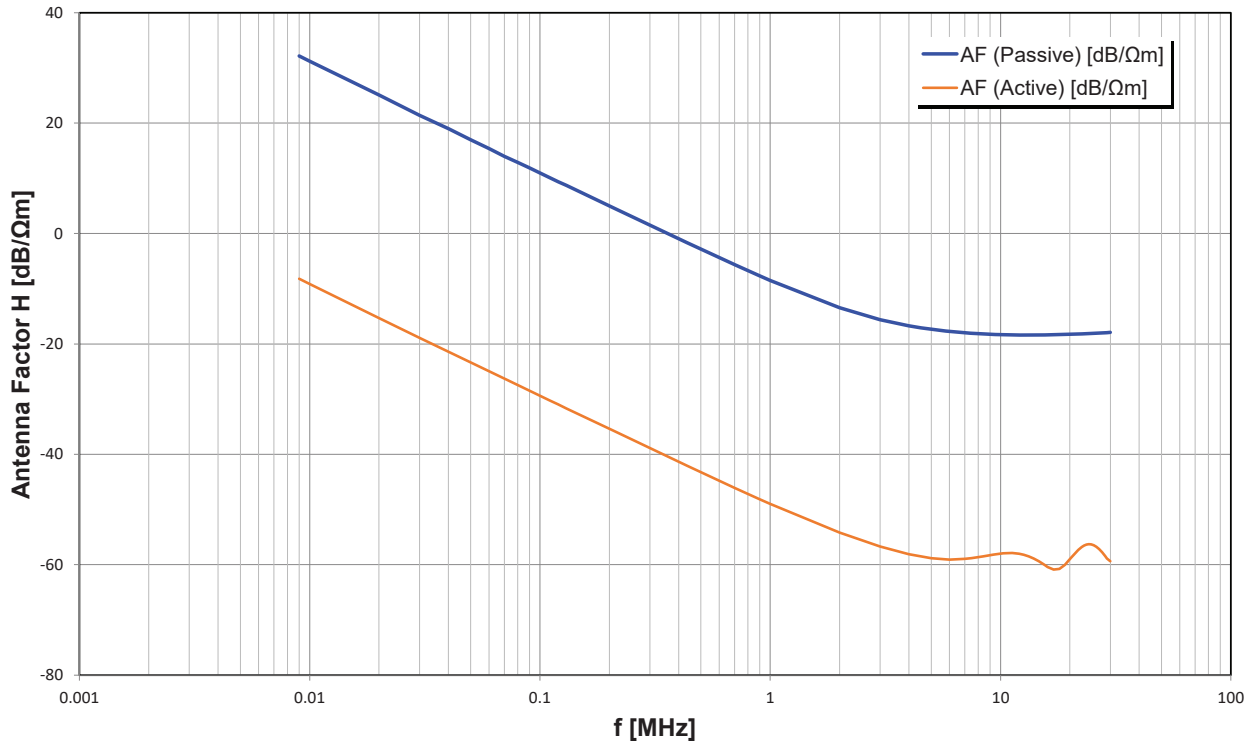


Table 1: Antenna Factor H; 9kHz-30MHz

f [MHz]	AF (Passive) [dB/Ωm]	AF (Active) [dB/Ωm]	U [dB]	f [MHz]	AF (Passive) [dB/Ωm]	AF (Active) [dB/Ωm]	U [dB]
0.009	32.17	-8.20	±1.20	5	-17.33	-58.82	±1.20
0.01	31.21	-9.16	±1.20	6	-17.75	-59.07	±1.20
0.02	25.09	-15.34	±1.20	7	-18.00	-58.93	±1.20
0.03	21.39	-18.89	±1.20	8	-18.15	-58.61	±1.20
0.04	18.98	-21.40	±1.20	9	-18.25	-58.26	±1.20
0.05	16.98	-23.35	±1.20	10	-18.30	-57.99	±1.20
0.06	15.39	-24.93	±1.20	11	-18.35	-57.88	±1.20
0.07	14.00	-26.27	±1.20	12	-18.39	-58.00	±1.20
0.08	12.87	-27.43	±1.20	13	-18.41	-58.34	±1.20
0.09	11.90	-28.45	±1.20	14	-18.40	-58.92	±1.20
0.1	10.97	-29.36	±1.20	15	-18.38	-59.66	±1.20
0.11	10.14	-30.20	±1.20	16	-18.34	-60.42	±1.20
0.12	9.38	-30.95	±1.20	17	-18.31	-60.88	±1.20
0.13	8.72	-31.65	±1.20	18	-18.29	-60.75	±1.20
0.14	8.07	-32.28	±1.20	19	-18.28	-60.02	±1.20
0.15	7.50	-32.88	±1.20	20	-18.26	-58.99	±1.20
0.2	4.98	-35.37	±1.20	21	-18.24	-57.96	±1.20
0.3	1.51	-38.86	±1.20	22	-18.19	-57.13	±1.20
0.4	-0.95	-41.33	±1.20	23	-18.15	-56.56	±1.20
0.5	-2.84	-43.23	±1.20	24	-18.11	-56.29	±1.20
0.6	-4.36	-44.77	±1.20	25	-18.07	-56.33	±1.20
0.7	-5.64	-46.06	±1.20	26	-18.05	-56.66	±1.20
0.8	-6.74	-47.17	±1.20	27	-18.03	-57.27	±1.20
0.9	-7.68	-48.13	±1.20	28	-18.00	-58.07	±1.20
1	-8.50	-48.98	±1.20	29	-17.96	-58.86	±1.20
2	-13.42	-54.16	±1.20	30	-17.90	-59.35	±1.20
3	-15.60	-56.70	±1.20				
4	-16.69	-58.08	±1.20				

## ANNEX VII. Sample Certificate of Sum of Antenna Factors

A sample calibration certificate for the PLA-Set is given on the following pages.

Kalibrierstelle für Antennen und Feldsonden  
*Calibration Body for Antennas and Field Probes*

Akkreditiert durch / *accredited by*  
**AKKREDITIERUNG AUSTRIA**



Kalibrierschein nach ISO/IEC 17025  
*Calibration Certificate according to ISO/IEC 17025*

Kalibrierzeichen  
*Calibration mark*

EH-XXXX/XX
<b>0612</b>

Gegenstand  
*Object*                      Set of Loop Antennas

Hersteller & Typ  
*Manufacturer & Type*        Seibersdorf Labor GmbH  
   PLA-T + PLA-R

Herstellernummer  
*Serial number*

Auftraggeber  
*Customer*

Auftragsnummer  
*Order Nr.*

Anzahl der Seiten des Kalibrierscheines    1 - 9  
*Number of pages of the certificate*

Datum und Ort der Kalibrierung  
*Date and place of calibration*

Akkreditierung Austria ist Vollmitglied bei der International Laboratory Accreditation Cooperation ILAC und Unterzeichner der MRAs für die Bereiche „Testing, Calibration and Inspection“.

Die Kalibrierung erfolgt auf der gesetzlichen Grundlage des Akkreditierungsgesetzes in gültiger Fassung entsprechend den Anforderungen der ÖVE/ÖNORM EN ISO/IEC 17025.

Dieser Kalibrierschein dokumentiert die Rückführbarkeit auf nationale Normale zur Darstellung der physikalischen Einheiten in Übereinstimmung mit dem Internationalen Einheitensystem (SI).

Für die Einhaltung einer angemessenen Frist zur Wiederholung der Kalibrierung ist der Benutzer verantwortlich.

*Akkreditierung Austria is a full member of the International Laboratory Accreditation Cooperation ILAC and a signatory of the MRA for "Testing, Calibration and Inspection".*

*The calibration is performed in accordance with the Akkreditierungsgesetz in the amended version and the requirements of ÖVE/ÖNORM EN ISO/IEC 17025.*

*This calibration certificate documents the traceability to national standards, which realize the physical units or measurements according to the International System of Units (SI).*

*The user is obliged to have the object recalibrated at appropriate intervals.*

Dieser Kalibrierschein gilt ausschließlich für den kalibrierten Gegenstand und darf nur vollständig und unverändert weiterverarbeitet werden. Auszüge oder Änderungen sind unzulässig. Kalibrierscheine ohne Unterschrift haben keine Gültigkeit.

*This calibration certificate is valid only for the calibrated object and may not be reproduced other than in full. Calibration certificates without signature are not valid.*

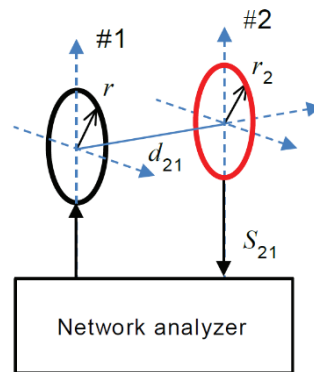
Datum  
*Date*

Zeichnungsberechtigter  
*Authorized person*

Bearbeiter  
*Person responsible*

## Calibration Procedure

Calibration of the **sum of antenna factors** of transmit and receive antenna is carried out according to the method described in internal process guideline LE-EH-VA-A02 (2022-07). The calibration fulfils the requirements of Normalized site insertion loss (NSIL) test site validation according to CISPR 16-1-4.



Calibrations are carried out on the Reference Open-Area Test Site at a height of 1.3 m, distance given in the results table.

## Test Equipment

Type	Identification
Network Analyzer Keysight E5061B	LE0215
Open Area Test Site	E1010
CalStan 11	E0921

## Environmental Conditions

Site Temperature	15 – 22 °C
Site Humidity	30 – 85 %
Control Temperature	22 – 27 °C
Control Humidity	30 - 80 %

## Results

Type	Description	Fig./Table
Sum of Antenna Factors	Broadband Mode, 9kHz-30MHz, d=0.3m	1
Sum of Antenna Factors	High Current Mode, 9kHz-200kHz, d=1m	2
Sum of Antenna Factors	Passive Mode, 9kHz-30MHz, d=0.3m	3

## Accuracy of Calibration

The reported expanded uncertainty of measurement is stated as the standard uncertainty of measurement multiplied by the coverage factor  $k = 2$ , which for a normal distribution corresponds to a coverage probability of approximately 95%. The standard uncertainty of measurement has been determined in accordance with EAL Publication EA 4/02.

## References

- [1] CISPR 16-1-4:2019/AMD1:2020/AMD2:2023 Specification for radio disturbance and immunity measuring apparatus and methods - Part 1-4: Radio disturbance and immunity measuring apparatus - Antennas and test sites for radiated disturbance measurements
- [2] EA-4/02 M: 2022 Evaluation of the Uncertainty of Measurement in calibration

Figure 1: Sum of Antenna Factors; Broadband Mode, 9kHz-30MHz, d=0.3m

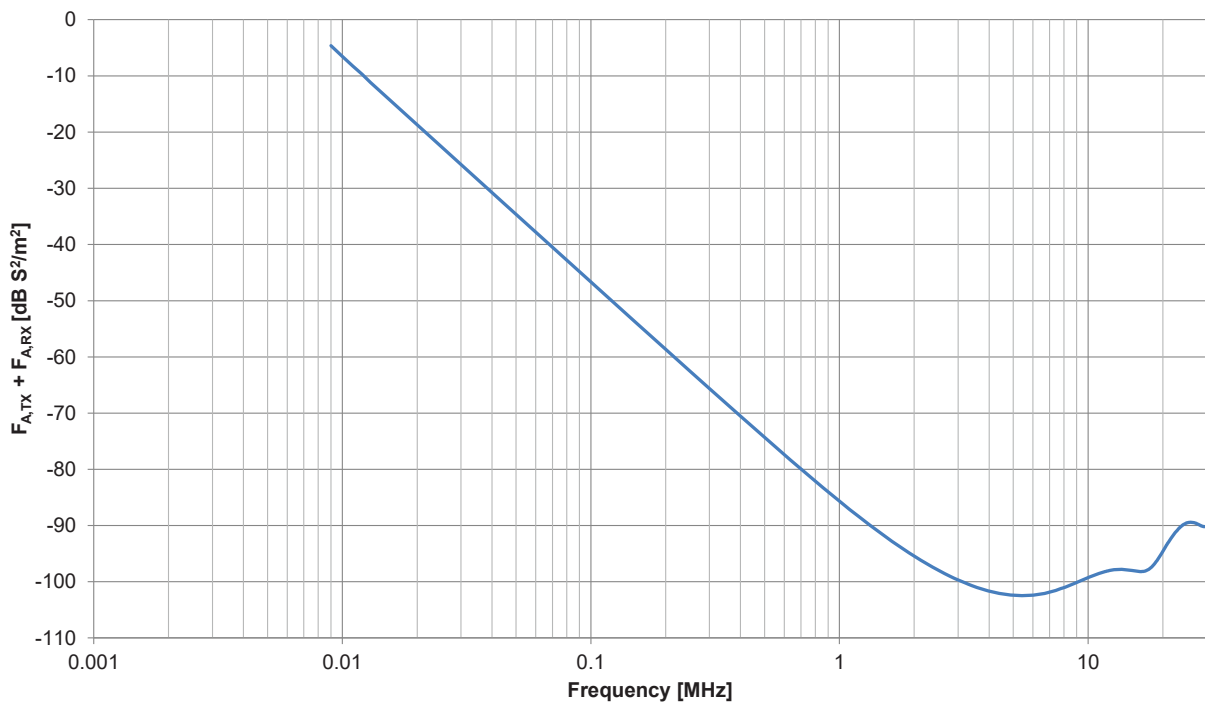


Table 1: Sum of Antenna Factors; Broadband Mode, 9kHz-30MHz, d=0.3m

f [MHz]	F <sub>A.TX</sub> +F <sub>A.RX</sub> [dB S <sup>2</sup> /m <sup>2</sup> ]	U[dB]	f [MHz]	F <sub>A.TX</sub> +F <sub>A.RX</sub> [dB S <sup>2</sup> /m <sup>2</sup> ]	U[dB]	f [MHz]	F <sub>A.TX</sub> +F <sub>A.RX</sub> [dB S <sup>2</sup> /m <sup>2</sup> ]	U[dB]
0.009	-4.64	±0.6	1.6	-92.58	±0.6	7.6	-101.39	±0.6
0.010	-6.53	±0.6	1.7	-93.39	±0.6	7.7	-101.30	±0.6
0.011	-8.22	±0.6	1.8	-94.15	±0.6	7.8	-101.22	±0.6
0.012	-9.70	±0.6	1.9	-94.83	±0.6	7.9	-101.13	±0.6
0.013	-11.16	±0.6	2.0	-95.46	±0.6	8.0	-101.05	±0.6
0.014	-12.44	±0.6	2.1	-96.05	±0.6	8.1	-100.95	±0.6
0.015	-13.64	±0.6	2.2	-96.58	±0.6	8.2	-100.86	±0.6
0.016	-14.79	±0.6	2.3	-97.08	±0.6	8.3	-100.77	±0.6
0.017	-15.86	±0.6	2.4	-97.54	±0.6	8.4	-100.68	±0.6
0.018	-16.85	±0.6	2.5	-97.96	±0.6	8.5	-100.59	±0.6
0.019	-17.77	±0.6	2.6	-98.36	±0.6	8.6	-100.50	±0.6
0.020	-18.68	±0.6	2.7	-98.73	±0.6	8.7	-100.41	±0.6
0.025	-22.59	±0.6	2.8	-99.07	±0.6	8.8	-100.32	±0.6
0.030	-25.73	±0.6	2.9	-99.39	±0.6	8.9	-100.23	±0.6
0.035	-28.44	±0.6	3.0	-99.68	±0.6	9.0	-100.14	±0.6
0.040	-30.75	±0.6	3.1	-99.95	±0.6	9.1	-100.05	±0.6
0.045	-32.81	±0.6	3.2	-100.21	±0.6	9.2	-99.96	±0.6
0.050	-34.65	±0.6	3.3	-100.45	±0.6	9.3	-99.87	±0.6
0.055	-36.29	±0.6	3.4	-100.66	±0.6	9.4	-99.78	±0.6
0.060	-37.81	±0.6	3.5	-100.86	±0.6	9.5	-99.69	±0.6
0.065	-39.20	±0.6	3.6	-101.06	±0.6	9.6	-99.61	±0.6
0.070	-40.49	±0.6	3.7	-101.22	±0.6	9.7	-99.53	±0.6
0.075	-41.68	±0.6	3.8	-101.38	±0.6	9.8	-99.44	±0.6
0.080	-42.81	±0.6	3.9	-101.53	±0.6	9.9	-99.36	±0.6
0.085	-43.86	±0.6	4.0	-101.67	±0.6	10.0	-99.27	±0.6
0.090	-44.84	±0.6	4.1	-101.78	±0.6	10.1	-99.20	±0.6
0.095	-45.79	±0.6	4.2	-101.89	±0.6	10.2	-99.13	±0.6
0.100	-46.68	±0.6	4.3	-101.99	±0.6	10.3	-99.05	±0.6
0.105	-47.53	±0.6	4.4	-102.08	±0.6	10.4	-98.98	±0.6
0.110	-48.33	±0.6	4.5	-102.16	±0.6	10.5	-98.91	±0.6
0.115	-49.10	±0.6	4.6	-102.23	±0.6	10.6	-98.84	±0.6
0.120	-49.84	±0.6	4.7	-102.29	±0.6	10.7	-98.77	±0.6
0.125	-50.54	±0.6	4.8	-102.35	±0.6	10.8	-98.70	±0.6
0.130	-51.22	±0.6	4.9	-102.40	±0.6	10.9	-98.65	±0.6
0.135	-51.88	±0.6	5.0	-102.43	±0.6	11.0	-98.58	±0.6
0.140	-52.51	±0.6	5.1	-102.45	±0.6	11.1	-98.52	±0.6
0.145	-53.11	±0.6	5.2	-102.47	±0.6	11.2	-98.46	±0.6
0.150	-53.70	±0.6	5.3	-102.48	±0.6	11.3	-98.41	±0.6
0.20	-58.67	±0.6	5.4	-102.49	±0.6	11.4	-98.36	±0.6
0.25	-62.52	±0.6	5.5	-102.50	±0.6	11.5	-98.31	±0.6
0.30	-65.65	±0.6	5.6	-102.48	±0.6	11.6	-98.26	±0.6
0.35	-68.29	±0.6	5.7	-102.47	±0.6	11.7	-98.21	±0.6
0.40	-70.57	±0.6	5.8	-102.45	±0.6	11.8	-98.17	±0.6
0.45	-72.57	±0.6	5.9	-102.43	±0.6	11.9	-98.13	±0.6
0.50	-74.34	±0.6	6.0	-102.40	±0.6	12.0	-98.09	±0.6
0.55	-75.95	±0.6	6.1	-102.36	±0.6	12.1	-98.05	±0.6
0.60	-77.40	±0.6	6.2	-102.33	±0.6	12.2	-98.02	±0.6
0.65	-78.72	±0.6	6.3	-102.28	±0.6	12.3	-97.98	±0.6
0.70	-79.95	±0.6	6.4	-102.23	±0.6	12.4	-97.96	±0.6
0.75	-81.08	±0.6	6.5	-102.18	±0.6	12.5	-97.92	±0.6
0.80	-82.12	±0.6	6.6	-102.12	±0.6	12.6	-97.90	±0.6
0.85	-83.10	±0.6	6.7	-102.06	±0.6	12.7	-97.88	±0.6
0.90	-84.02	±0.6	6.8	-101.99	±0.6	12.8	-97.86	±0.6
0.95	-84.88	±0.6	6.9	-101.93	±0.6	12.9	-97.85	±0.6
1.0	-85.67	±0.6	7.0	-101.86	±0.6	13.0	-97.83	±0.6
1.1	-87.15	±0.6	7.1	-101.78	±0.6	13.1	-97.82	±0.6
1.2	-88.46	±0.6	7.2	-101.71	±0.6	13.2	-97.82	±0.6
1.3	-89.65	±0.6	7.3	-101.63	±0.6	13.3	-97.80	±0.6
1.4	-90.73	±0.6	7.4	-101.55	±0.6	13.4	-97.80	±0.6
1.5	-91.69	±0.6	7.5	-101.46	±0.6	13.5	-97.80	±0.6

f [MHz]	F <sub>A.TX</sub> +F <sub>A.RX</sub> [dB S <sup>2</sup> /m <sup>2</sup> ]	U[dB]	f [MHz]	F <sub>A.TX</sub> +F <sub>A.RX</sub> [dB S <sup>2</sup> /m <sup>2</sup> ]	U[dB]	f [MHz]	F <sub>A.TX</sub> +F <sub>A.RX</sub> [dB S <sup>2</sup> /m <sup>2</sup> ]	U[dB]
13.6	-97.80	±0.6	19.1	-96.01	±0.6	24.6	-89.66	±0.6
13.7	-97.80	±0.6	19.2	-95.85	±0.6	24.7	-89.64	±0.6
13.8	-97.81	±0.6	19.3	-95.70	±0.6	24.8	-89.59	±0.6
13.9	-97.81	±0.6	19.4	-95.55	±0.6	24.9	-89.56	±0.6
14.0	-97.82	±0.6	19.5	-95.39	±0.6	25.0	-89.53	±0.6
14.1	-97.83	±0.6	19.6	-95.23	±0.6	25.1	-89.51	±0.6
14.2	-97.85	±0.6	19.7	-95.08	±0.6	25.2	-89.48	±0.6
14.3	-97.86	±0.6	19.8	-94.92	±0.6	25.3	-89.47	±0.6
14.4	-97.88	±0.6	19.9	-94.77	±0.6	25.4	-89.45	±0.6
14.5	-97.89	±0.6	20.0	-94.60	±0.6	25.5	-89.44	±0.6
14.6	-97.92	±0.6	20.1	-94.44	±0.6	25.6	-89.42	±0.6
14.7	-97.93	±0.6	20.2	-94.28	±0.6	25.7	-89.43	±0.6
14.8	-97.95	±0.6	20.3	-94.13	±0.6	25.8	-89.42	±0.6
14.9	-97.98	±0.6	20.4	-93.97	±0.6	25.9	-89.42	±0.6
15.0	-97.99	±0.6	20.5	-93.82	±0.6	26.0	-89.42	±0.6
15.1	-98.01	±0.6	20.6	-93.67	±0.6	26.1	-89.42	±0.6
15.2	-98.03	±0.6	20.7	-93.51	±0.6	26.2	-89.43	±0.6
15.3	-98.05	±0.6	20.8	-93.37	±0.6	26.3	-89.45	±0.6
15.4	-98.08	±0.6	20.9	-93.22	±0.6	26.4	-89.45	±0.6
15.5	-98.10	±0.6	21.0	-93.07	±0.6	26.5	-89.46	±0.6
15.6	-98.12	±0.6	21.1	-92.93	±0.6	26.6	-89.49	±0.6
15.7	-98.14	±0.6	21.2	-92.79	±0.6	26.7	-89.50	±0.6
15.8	-98.15	±0.6	21.3	-92.64	±0.6	26.8	-89.53	±0.6
15.9	-98.17	±0.6	21.4	-92.52	±0.6	26.9	-89.55	±0.6
16.0	-98.18	±0.6	21.5	-92.38	±0.6	27.0	-89.58	±0.6
16.1	-98.19	±0.6	21.6	-92.25	±0.6	27.1	-89.59	±0.6
16.2	-98.19	±0.6	21.7	-92.12	±0.6	27.2	-89.62	±0.6
16.3	-98.20	±0.6	21.8	-91.99	±0.6	27.3	-89.65	±0.6
16.4	-98.20	±0.6	21.9	-91.88	±0.6	27.4	-89.67	±0.6
16.5	-98.19	±0.6	22.0	-91.75	±0.6	27.5	-89.71	±0.6
16.6	-98.18	±0.6	22.1	-91.64	±0.6	27.6	-89.75	±0.6
16.7	-98.16	±0.6	22.2	-91.52	±0.6	27.7	-89.78	±0.6
16.8	-98.14	±0.6	22.3	-91.41	±0.6	27.8	-89.81	±0.6
16.9	-98.12	±0.6	22.4	-91.30	±0.6	27.9	-89.85	±0.6
17.0	-98.08	±0.6	22.5	-91.19	±0.6	28.0	-89.87	±0.6
17.1	-98.05	±0.6	22.6	-91.09	±0.6	28.1	-89.91	±0.6
17.2	-98.01	±0.6	22.7	-90.99	±0.6	28.2	-89.95	±0.6
17.3	-97.95	±0.6	22.8	-90.89	±0.6	28.3	-89.98	±0.6
17.4	-97.90	±0.6	22.9	-90.80	±0.6	28.4	-90.01	±0.6
17.5	-97.82	±0.6	23.0	-90.70	±0.6	28.5	-90.04	±0.6
17.6	-97.76	±0.6	23.1	-90.61	±0.6	28.6	-90.07	±0.6
17.7	-97.69	±0.6	23.2	-90.53	±0.6	28.7	-90.10	±0.6
17.8	-97.60	±0.6	23.3	-90.44	±0.6	28.8	-90.12	±0.6
17.9	-97.51	±0.6	23.4	-90.37	±0.6	28.9	-90.15	±0.6
18.0	-97.42	±0.6	23.5	-90.28	±0.6	29.0	-90.16	±0.6
18.1	-97.31	±0.6	23.6	-90.22	±0.6	29.1	-90.19	±0.6
18.2	-97.20	±0.6	23.7	-90.15	±0.6	29.2	-90.20	±0.6
18.3	-97.09	±0.6	23.8	-90.09	±0.6	29.3	-90.21	±0.6
18.4	-96.97	±0.6	23.9	-90.02	±0.6	29.4	-90.21	±0.6
18.5	-96.84	±0.6	24.0	-89.96	±0.6	29.5	-90.21	±0.6
18.6	-96.71	±0.6	24.1	-89.90	±0.6	29.6	-90.21	±0.6
18.7	-96.58	±0.6	24.2	-89.85	±0.6	29.7	-90.20	±0.6
18.8	-96.44	±0.6	24.3	-89.80	±0.6	29.8	-90.18	±0.6
18.9	-96.30	±0.6	24.4	-89.75	±0.6	29.9	-90.16	±0.6
19.0	-96.16	±0.6	24.5	-89.70	±0.6	30.0	-90.14	±0.6

Figure 2: Sum of Antenna Factors; High Current Mode, 9kHz-200kHz, d=1m

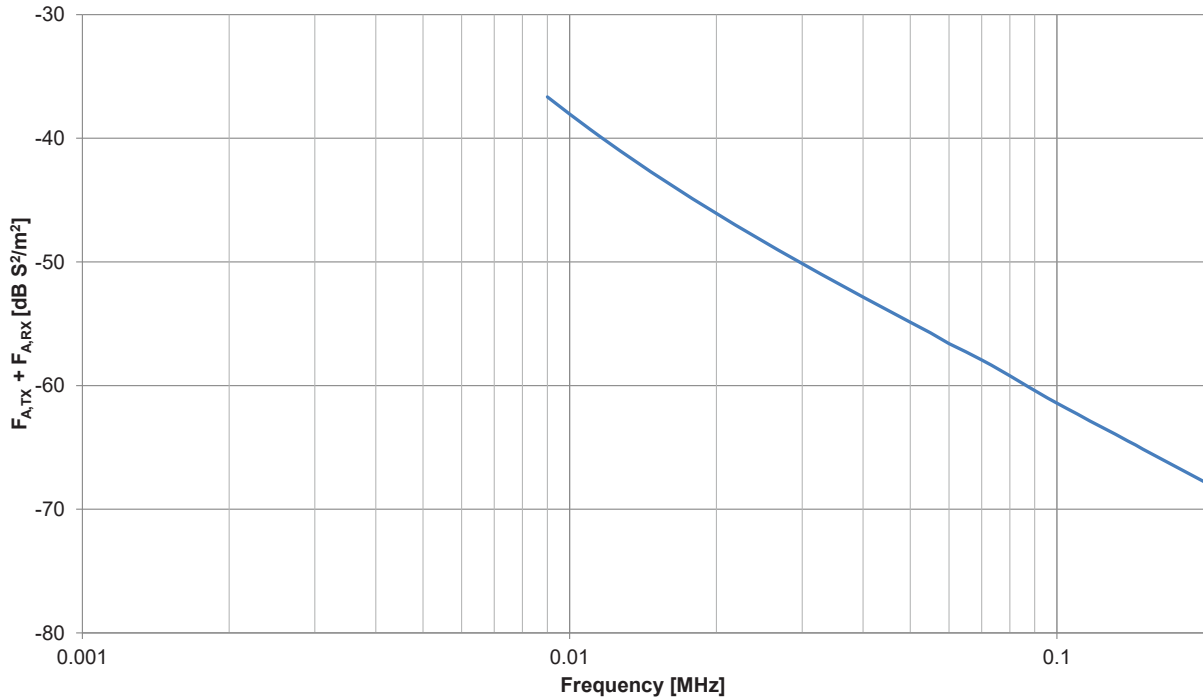


Table 2: Sum of Antenna Factors; High Current Mode, 9kHz-200kHz, d=1m

f [MHz]	$F_{A.TX}+F_{A.RX}$ [dB S <sup>2</sup> /m <sup>2</sup> ]	U[dB]	f [MHz]	$F_{A.TX}+F_{A.RX}$ [dB S <sup>2</sup> /m <sup>2</sup> ]	U[dB]	f [MHz]	$F_{A.TX}+F_{A.RX}$ [dB S <sup>2</sup> /m <sup>2</sup> ]	U[dB]
0.009	-36.65	±0.6	0.030	-50.13	±0.6	0.095	-60.92	±0.6
0.010	-38.05	±0.6	0.035	-51.60	±0.6	0.100	-61.43	±0.6
0.011	-39.26	±0.6	0.040	-52.85	±0.6	0.105	-61.88	±0.6
0.012	-40.35	±0.6	0.045	-53.93	±0.6	0.110	-62.30	±0.6
0.013	-41.30	±0.6	0.050	-54.90	±0.6	0.115	-62.71	±0.6
0.014	-42.17	±0.6	0.055	-55.74	±0.6	0.120	-63.11	±0.6
0.015	-42.96	±0.6	0.060	-56.60	±0.6	0.125	-63.46	±0.6
0.016	-43.68	±0.6	0.065	-57.26	±0.6	0.130	-63.81	±0.6
0.017	-44.35	±0.6	0.070	-57.93	±0.6	0.135	-64.16	±0.6
0.018	-44.96	±0.6	0.075	-58.55	±0.6	0.140	-64.50	±0.6
0.019	-45.54	±0.6	0.080	-59.21	±0.6	0.145	-64.81	±0.6
0.020	-46.08	±0.6	0.085	-59.83	±0.6	0.150	-65.14	±0.6
0.025	-48.34	±0.6	0.090	-60.41	±0.6	0.20	-67.76	±0.6

Figure 3: Sum of Antenna Factors; Passive Mode, 9kHz-30MHz, d=0.3m

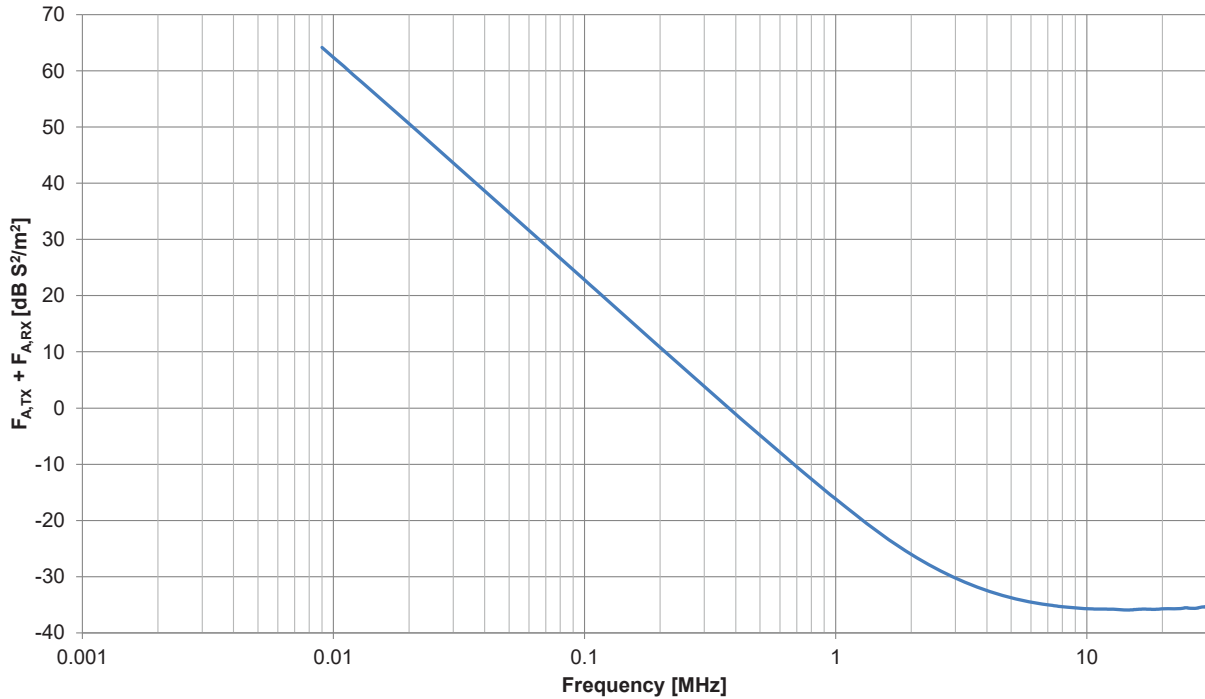


Table 3: Sum of Antenna Factors; Passive Mode, 9kHz-30MHz, d=0.3m

f [MHz]	$F_{A,TX}+F_{A,RX}$ [dB S <sup>2</sup> /m <sup>2</sup> ]	U[dB]	f [MHz]	$F_{A,TX}+F_{A,RX}$ [dB S <sup>2</sup> /m <sup>2</sup> ]	U[dB]	f [MHz]	$F_{A,TX}+F_{A,RX}$ [dB S <sup>2</sup> /m <sup>2</sup> ]	U[dB]
0.009	64.18	±1.0	0.105	21.94	±1.0	1.2	-18.98	±1.0
0.010	62.38	±1.0	0.110	21.13	±1.0	1.3	-20.17	±1.0
0.011	60.80	±1.0	0.115	20.36	±1.0	1.4	-21.25	±1.0
0.012	59.28	±1.0	0.120	19.62	±1.0	1.5	-22.23	±1.0
0.013	57.93	±1.0	0.125	18.92	±1.0	1.6	-23.13	±1.0
0.014	56.69	±1.0	0.130	18.24	±1.0	1.7	-23.95	±1.0
0.015	55.53	±1.0	0.135	17.60	±1.0	1.8	-24.70	±1.0
0.016	54.46	±1.0	0.140	16.96	±1.0	1.9	-25.39	±1.0
0.017	53.39	±1.0	0.145	16.35	±1.0	2.0	-26.02	±1.0
0.018	52.33	±1.0	0.150	15.76	±1.0	2.1	-26.61	±1.0
0.019	51.46	±1.0	0.20	10.79	±1.0	2.2	-27.15	±1.0
0.020	50.62	±1.0	0.25	6.95	±1.0	2.3	-27.65	±1.0
0.025	46.73	±1.0	0.30	3.82	±1.0	2.4	-28.11	±1.0
0.030	43.62	±1.0	0.35	1.18	±1.0	2.5	-28.54	±1.0
0.035	40.93	±1.0	0.40	-1.09	±1.0	2.6	-28.94	±1.0
0.040	38.65	±1.0	0.45	-3.09	±1.0	2.7	-29.31	±1.0
0.045	36.62	±1.0	0.50	-4.86	±1.0	2.8	-29.66	±1.0
0.050	34.78	±1.0	0.55	-6.46	±1.0	2.9	-29.98	±1.0
0.055	33.13	±1.0	0.60	-7.91	±1.0	3.0	-30.28	±1.0
0.060	31.62	±1.0	0.65	-9.24	±1.0	3.1	-30.57	±1.0
0.065	30.26	±1.0	0.70	-10.46	±1.0	3.2	-30.83	±1.0
0.070	28.96	±1.0	0.75	-11.59	±1.0	3.3	-31.08	±1.0
0.075	27.77	±1.0	0.80	-12.63	±1.0	3.4	-31.32	±1.0
0.080	26.65	±1.0	0.85	-13.61	±1.0	3.5	-31.54	±1.0
0.085	25.59	±1.0	0.90	-14.52	±1.0	3.6	-31.75	±1.0
0.090	24.61	±1.0	0.95	-15.38	±1.0	3.7	-31.95	±1.0
0.095	23.67	±1.0	1.0	-16.18	±1.0	3.8	-32.13	±1.0
0.100	22.79	±1.0	1.1	-17.66	±1.0	3.9	-32.31	±1.0

f [MHz]	F <sub>A,TX</sub> +F <sub>A,RX</sub> [dB S <sup>2</sup> /m <sup>2</sup> ]	U [dB]	f [MHz]	F <sub>A,TX</sub> +F <sub>A,RX</sub> [dB S <sup>2</sup> /m <sup>2</sup> ]	U [dB]	f [MHz]	F <sub>A,TX</sub> +F <sub>A,RX</sub> [dB S <sup>2</sup> /m <sup>2</sup> ]	U [dB]
4.0	-32.48	±1.0	10.4	-35.74	±1.0	16.8	-35.78	±1.0
4.1	-32.64	±1.0	10.5	-35.75	±1.0	16.9	-35.79	±1.0
4.2	-32.79	±1.0	10.6	-35.75	±1.0	17.0	-35.78	±1.0
4.3	-32.93	±1.0	10.7	-35.76	±1.0	17.1	-35.78	±1.0
4.4	-33.07	±1.0	10.8	-35.76	±1.0	17.2	-35.79	±1.0
4.5	-33.19	±1.0	10.9	-35.77	±1.0	17.3	-35.79	±1.0
4.6	-33.32	±1.0	11.0	-35.77	±1.0	17.4	-35.80	±1.0
4.7	-33.43	±1.0	11.1	-35.77	±1.0	17.5	-35.80	±1.0
4.8	-33.54	±1.0	11.2	-35.78	±1.0	17.6	-35.80	±1.0
4.9	-33.65	±1.0	11.3	-35.78	±1.0	17.7	-35.80	±1.0
5.0	-33.75	±1.0	11.4	-35.78	±1.0	17.8	-35.81	±1.0
5.1	-33.84	±1.0	11.5	-35.78	±1.0	17.9	-35.81	±1.0
5.2	-33.93	±1.0	11.6	-35.78	±1.0	18.0	-35.81	±1.0
5.3	-34.02	±1.0	11.7	-35.78	±1.0	18.1	-35.82	±1.0
5.4	-34.10	±1.0	11.8	-35.78	±1.0	18.2	-35.82	±1.0
5.5	-34.18	±1.0	11.9	-35.79	±1.0	18.3	-35.82	±1.0
5.6	-34.25	±1.0	12.0	-35.79	±1.0	18.4	-35.83	±1.0
5.7	-34.32	±1.0	12.1	-35.79	±1.0	18.5	-35.83	±1.0
5.8	-34.39	±1.0	12.2	-35.79	±1.0	18.6	-35.83	±1.0
5.9	-34.45	±1.0	12.3	-35.79	±1.0	18.7	-35.82	±1.0
6.0	-34.51	±1.0	12.4	-35.79	±1.0	18.8	-35.82	±1.0
6.1	-34.57	±1.0	12.5	-35.80	±1.0	18.9	-35.82	±1.0
6.2	-34.63	±1.0	12.6	-35.81	±1.0	19.0	-35.82	±1.0
6.3	-34.68	±1.0	12.7	-35.81	±1.0	19.1	-35.80	±1.0
6.4	-34.74	±1.0	12.8	-35.82	±1.0	19.2	-35.80	±1.0
6.5	-34.79	±1.0	12.9	-35.82	±1.0	19.3	-35.79	±1.0
6.6	-34.84	±1.0	13.0	-35.83	±1.0	19.4	-35.78	±1.0
6.7	-34.88	±1.0	13.1	-35.84	±1.0	19.5	-35.77	±1.0
6.8	-34.93	±1.0	13.2	-35.85	±1.0	19.6	-35.76	±1.0
6.9	-34.97	±1.0	13.3	-35.85	±1.0	19.7	-35.75	±1.0
7.0	-35.01	±1.0	13.4	-35.86	±1.0	19.8	-35.74	±1.0
7.1	-35.05	±1.0	13.5	-35.87	±1.0	19.9	-35.73	±1.0
7.2	-35.09	±1.0	13.6	-35.88	±1.0	20.0	-35.73	±1.0
7.3	-35.13	±1.0	13.7	-35.89	±1.0	20.1	-35.72	±1.0
7.4	-35.16	±1.0	13.8	-35.89	±1.0	20.2	-35.71	±1.0
7.5	-35.20	±1.0	13.9	-35.90	±1.0	20.3	-35.70	±1.0
7.6	-35.23	±1.0	14.0	-35.91	±1.0	20.4	-35.70	±1.0
7.7	-35.26	±1.0	14.1	-35.91	±1.0	20.5	-35.69	±1.0
7.8	-35.29	±1.0	14.2	-35.91	±1.0	20.6	-35.68	±1.0
7.9	-35.32	±1.0	14.3	-35.92	±1.0	20.7	-35.68	±1.0
8.0	-35.35	±1.0	14.4	-35.92	±1.0	20.8	-35.69	±1.0
8.1	-35.37	±1.0	14.5	-35.92	±1.0	20.9	-35.68	±1.0
8.2	-35.40	±1.0	14.6	-35.92	±1.0	21.0	-35.68	±1.0
8.3	-35.42	±1.0	14.7	-35.92	±1.0	21.1	-35.69	±1.0
8.4	-35.45	±1.0	14.8	-35.92	±1.0	21.2	-35.69	±1.0
8.5	-35.47	±1.0	14.9	-35.91	±1.0	21.3	-35.70	±1.0
8.6	-35.49	±1.0	15.0	-35.91	±1.0	21.4	-35.70	±1.0
8.7	-35.51	±1.0	15.1	-35.90	±1.0	21.5	-35.70	±1.0
8.8	-35.53	±1.0	15.2	-35.89	±1.0	21.6	-35.71	±1.0
8.9	-35.54	±1.0	15.3	-35.89	±1.0	21.7	-35.72	±1.0
9.0	-35.56	±1.0	15.4	-35.88	±1.0	21.8	-35.72	±1.0
9.1	-35.58	±1.0	15.5	-35.87	±1.0	21.9	-35.73	±1.0
9.2	-35.60	±1.0	15.6	-35.86	±1.0	22.0	-35.73	±1.0
9.3	-35.61	±1.0	15.7	-35.85	±1.0	22.1	-35.74	±1.0
9.4	-35.63	±1.0	15.8	-35.84	±1.0	22.2	-35.74	±1.0
9.5	-35.64	±1.0	15.9	-35.83	±1.0	22.3	-35.75	±1.0
9.6	-35.65	±1.0	16.0	-35.82	±1.0	22.4	-35.75	±1.0
9.7	-35.67	±1.0	16.1	-35.82	±1.0	22.5	-35.75	±1.0
9.8	-35.68	±1.0	16.2	-35.81	±1.0	22.6	-35.75	±1.0
9.9	-35.69	±1.0	16.3	-35.80	±1.0	22.7	-35.74	±1.0
10.0	-35.70	±1.0	16.4	-35.80	±1.0	22.8	-35.74	±1.0
10.1	-35.72	±1.0	16.5	-35.79	±1.0	22.9	-35.74	±1.0
10.2	-35.72	±1.0	16.6	-35.79	±1.0	23.0	-35.74	±1.0
10.3	-35.73	±1.0	16.7	-35.78	±1.0	23.1	-35.72	±1.0

f [MHz]	F <sub>A,TX</sub> +F <sub>A,RX</sub> [dB S <sup>2</sup> /m <sup>2</sup> ]	U[dB]	f [MHz]	F <sub>A,TX</sub> +F <sub>A,RX</sub> [dB S <sup>2</sup> /m <sup>2</sup> ]	U[dB]	f [MHz]	F <sub>A,TX</sub> +F <sub>A,RX</sub> [dB S <sup>2</sup> /m <sup>2</sup> ]	U[dB]
23.2	-35.71	±1.0	25.5	-35.58	±1.0	27.8	-35.54	±1.0
23.3	-35.71	±1.0	25.6	-35.59	±1.0	27.9	-35.53	±1.0
23.4	-35.69	±1.0	25.7	-35.60	±1.0	28.0	-35.51	±1.0
23.5	-35.68	±1.0	25.8	-35.61	±1.0	28.1	-35.49	±1.0
23.6	-35.66	±1.0	25.9	-35.61	±1.0	28.2	-35.48	±1.0
23.7	-35.65	±1.0	26.0	-35.63	±1.0	28.3	-35.47	±1.0
23.8	-35.63	±1.0	26.1	-35.63	±1.0	28.4	-35.46	±1.0
23.9	-35.63	±1.0	26.2	-35.64	±1.0	28.5	-35.45	±1.0
24.0	-35.61	±1.0	26.3	-35.64	±1.0	28.6	-35.43	±1.0
24.1	-35.60	±1.0	26.4	-35.65	±1.0	28.7	-35.42	±1.0
24.2	-35.59	±1.0	26.5	-35.65	±1.0	28.8	-35.41	±1.0
24.3	-35.58	±1.0	26.6	-35.65	±1.0	28.9	-35.40	±1.0
24.4	-35.57	±1.0	26.7	-35.65	±1.0	29.0	-35.40	±1.0
24.5	-35.56	±1.0	26.8	-35.65	±1.0	29.1	-35.39	±1.0
24.6	-35.56	±1.0	26.9	-35.64	±1.0	29.2	-35.39	±1.0
24.7	-35.56	±1.0	27.0	-35.64	±1.0	29.3	-35.38	±1.0
24.8	-35.55	±1.0	27.1	-35.63	±1.0	29.4	-35.38	±1.0
24.9	-35.55	±1.0	27.2	-35.62	±1.0	29.5	-35.38	±1.0
25.0	-35.55	±1.0	27.3	-35.61	±1.0	29.6	-35.38	±1.0
25.1	-35.56	±1.0	27.4	-35.60	±1.0	29.7	-35.39	±1.0
25.2	-35.56	±1.0	27.5	-35.59	±1.0	29.8	-35.39	±1.0
25.3	-35.57	±1.0	27.6	-35.58	±1.0	29.9	-35.39	±1.0
25.4	-35.57	±1.0	27.7	-35.56	±1.0	30.0	-35.39	±1.0

## **CONTACT**

**Seibersdorf Labor GmbH**  
EMC & Optics  
2444 Seibersdorf, Austria

[www.seibersdorf-laboratories.at](http://www.seibersdorf-laboratories.at)  
+43 50550 - 2882

[www.seibersdorf-rf.com](http://www.seibersdorf-rf.com)