

BEAM PROPAGATION MODEL FOR THE HAZARD EVALUATION OF GAUSSIAN LASER BEAMS

STRAHLFORTPFLANZUGSMODELL FÜR DIE GEFÄHRDUNGSBEURTEILUNG VON GAUSSCHEN LASERSTRAHLEN

Karl Schulmeister, Sandra Althaus, Ulfried Grabner and Georg Veas

ARC Seibersdorf research GmbH, Seibersdorf, AUSTRIA

Summary A beam propagation model was developed to calculate the most hazardous position, the angular subtense of the apparent source, and the power that passes through a 7 mm at that position for a Gaussian laser beam. The results for the thermal retinal hazard are discussed and it is shown that for most cases, at the most hazardous position, the beam waist can be treated as the apparent source. A number of distinctive regions of beam waist diameter and divergence values could be identified and the background of the results of the model could be explained and approximated well by simple formulas. Since the angular subtense of the beam waist (and therefore of the apparent source) decreases with increasing distance to the beam waist, the most hazardous position may not be at 10 cm from the beam waist but some distance away. Consequently, when the results of the model are compared with the accessible emission level and the emission limit that would be determined at 10 cm from the beam waist, as is currently implied in the international laser safety standard IEC 60825-1, then the latter would underestimate the hazard by up to a factor of 3.5.

Zusammenfassung — Ein Strahlfortpflanzungsmodell wurde entwickelt mit dem der Ort der größten Gefahr, der Leistung die durch eine Blende von 7 mm Durchmesser tritt, sowie die Ausdehnung der scheinbaren Quellen am Ort der größten Gefahr für einen Gaußschen Laserstrahl berechnet werden kann. Die Ergebnisse für den thermischen Netzhautschaden werden diskutiert und es wird gezeigt, dass in den meisten Fällen die Strahltaille die scheinbare Quelle darstellt. Verschiedene Bereiche von Taillendurchmessern und Divergenzen konnten identifiziert und die Ergebnisse der Modellrechnungen erklärt werden, wobei auch vereinfachte Formeln gefunden wurden. Da die Winkelausdehnung der des Strahlprofils am Ort der Taille (und damit der scheinbaren Quelle) mit der Entfernung von der Taille abnimmt, ist der Ort der größten Gefahr in vielen Fällen nicht in 10 cm Abstand von der Taille, sondern weiter entfernt. Ein Vergleich der Ergebnisse des Modells mit den Werten der zugänglichen Strahlung und der Grenzwerte die bei einer Entfernung von 10 cm bestimmt werden, wie zur Zeit in der internationalen Lasersicherheitsnorm IEC 60825-1 vorgesehen, zeigt, dass folgend letzterer das Gefährdungspotential um bis zu einem Faktor 3.5 unterschätzt werden kann.

Schlüsselwörter — Strahlfortpflanzung, Laserstrahl, Ort der größten Gefahr, thermischer Netzhautschaden, Ausdehnung der scheinbaren Quelle

Keywords — Beam propagation, laser beam, maximum hazard position, thermal retinal hazard, angular subtense of the apparent source

1. Introduction

For a complete and general hazard analysis of laser radiation in the wavelength range of 400 nm to 1400 nm, where the retina can be affected thermally, it needs to be considered that both the power $P(z)$ that passes through the 7 mm measurement aperture and the angular subtense of the apparent source $\alpha(z)$ depend on the position of the point of determination of these quantities in the beam z (where z is measured from the position of the beam waist) [1]. Since $P(z)$ is the power that is to be compared to the emission or exposure limit (AEL or MPE, respectively, as for instance defined in the international laser safety standard IEC 60825-1), and the thermal retinal MPE and the corresponding AEL for Class 1, 1M, 2, 2M and 3R depend on α , the dependence of both parameters on the distance to the beam waist need to be considered for a complete hazard analysis.

The parameter α , the “angular subtense of the apparent source” is defined as the angular subtense of the smallest (most hazardous) retinal image that can be obtained by considering different states of accommodation of the eye. Therefore, for each position z of the eye in the beam, the accommodation condition of the eye is varied between the near point of the eye, assumed in the international laser safety standard as 10 cm, and infinity, i.e. the condition of the relaxed eye. This can be done experimentally, or, for the case of Gaussian beams, an analytical formula can be derived [2]. Thus the most hazardous position (MHP) can be defined as the position where the ratio of exposure over exposure limit (or accessible emission over emission limit when the analysis is used for classification of laser products) is at its maximum.

MHP = z where $\frac{P(z)}{\alpha(z)}$ is maximum, as indicated in figure 1.

The ratio $P(z)/\alpha(z)$ can also be referred to as the relative thermal hazard, RTH.

Following the principle of performing the evaluation at the most hazardous position, the exposure/emission level and the exposure/emission limit is determined at the MHP for a given laser beam.

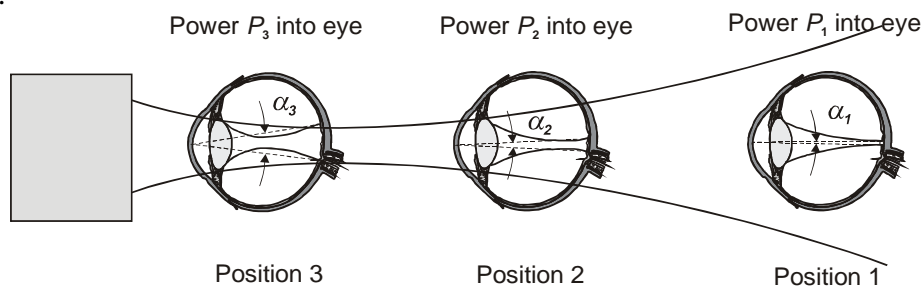

Fig. 1: For the most general laser safety analysis, the power that enters the eye at different positions in the beam needs to be characterised and compared to the MPE (or the AEL for classification). As the MPE values for the retinal thermal hazard depend on α , they are different for different exposure positions.

This concept of the MHP is discussed in more detail in [1] but also in the previous paper of these proceedings (in German language).

2. Basic Model Structure

A computer model was developed to vary both the position of the eye within a Gaussian beam and for each position, to calculate the power that passes through a 7 mm lens and the angular subtense of the apparent source. The input parameters, the beam waist diameter and divergence of the beam, were varied over ranges to cover most laser systems. The model produces the following output parameters for the matrix of beams characterised by the range of divergence and the beam waist diameters:

- Most hazardous position (distance z_{haz} between MHP and the primary beam waist)
- α at the MHP
- Power P through 7 mm aperture at the MHP
- Ratio of P/ α (the RHL)

The human eye was modelled in a simplified way, by assuming a simple thin lens in air, with a focal length varying between 17 mm for the relaxed eye and 14.53 mm for the near point of 10 cm, with a distance of the retina to the principle plane of the lens of 17 mm.

The model is based on a relatively simple beam propagation formalism which describes how the beam diameter varies as function of propagation, including transformation by ideal lenses [2]. When the beam diameter is determined according to the second moment method as described in ISO 11146 [3], then the beam propagation formalism does not only apply to Gaussian beams, but to any kind of beam of optical radiation. However, the problem, as discussed further below, is that the single parameter “beam diameter” can not convey the information of the actual beam profile. This is a serious limitation as both the power that enters the eye and the hazard of the retinal image can be grossly underestimated when the second moment beam diameter definition is used and the model is applied to non-Gaussian beams. Only for Gaussian beam (zero order TEM₀₀) does one know the irradiance profile at the cornea and at the retina, as it is always Gaussian. Therefore, in the strict sense, the model should only be applied to Gaussian beams. However, it is still useful to model the full range of combinations of beam waist diameter and divergence, which can only be realised by higher order beams with a beam parameter product M^2 greater than 1 to discuss the general principle and dependencies. In the model calculations, M^2 values between 1 and 1000 were modelled.

The beam propagation formalism describes the transformation of a primary beam waist (with a certain beam waist diameter) and far field divergence into a secondary beam waist with a secondary far field divergence on the other side of the lens. The basic concept of the model is the same as discussed in [4] but we have used the formula given in [5] which yields the focal length of the lens to produce the minimal retinal spot size for a given beam and for a given position of the lens in the beam and we could accurately model small beam divergence and small beam diameter values (which are the most common ones) by a logarithmic increase of the two parameters. The logarithmic scaling also favoured the identification of distinctive regions and the understanding of the background of the result of the model in relatively simple terms, which are presented further below.

In the model, the position of the eye relative to the beam waist was varied between 0 and 2 m, in 0.01 m steps. For the calculation of the retinal spot size, no diffraction effects or effects of the aperture on the beam were considered, i.e. for the calculation of the retinal spot size, the lens was assumed to be of infinite diameter (or at least much larger as the beam diameter). This represents a worst case assumption, as aperture effects would lead to a spreading of the retinal spot. The aperture diameter of 7 mm, however, was used to calculate the power that

passes through the 7 mm aperture, with the assumption of a Gaussian beam profile (and with the aperture located at the centre of the Gaussian profile). Since the second moment definition was used for the model, it needs to be considered that for a Gaussian beam profile, the second moment definitions of diameter d_σ and therefore also the far field divergence θ_σ correspond to the $1/e^2$ diameter definition of a Gaussian (the diameter at which the local irradiance is $1/e^2$ of the maximum central irradiance). The angular subtense of the apparent source (the angular subtense of the minimal retinal spot) was however calculated with the $1/e$ diameter criterion, and with the assumption that the retinal spot profile has a top-hat shape. This top-hat has a diameter that is at the $1/e$ levels of the Gaussian, so that the irradiance level within the top-hat is equal to the maximum irradiance of a Gaussian profile. This might seem somewhat inconsistent with the limitation of the model to Gaussian beams, however, only makes a difference when the retinal spot diameter becomes large enough so that it extends beyond an area which corresponds to 100 mrad (1.7 mm). Since α is limited in IEC 60825-1 [6] to 100 mrad and since an acceptance angle for the determination of the emission/exposure level of 100 mrad is defined, also only the fractional power which lies within 100 mrad of the image needs to be considered. When a top-hat retinal irradiance profile is assumed rather than a Gaussian, then the cases where the retinal spot is smaller than 100 mrad can be more clearly identified, as for a Gaussian with basically infinite extent, there is always some (minimal) fraction of the power that lies outside of 100 mrad. Another reason why the model is based on the assumption of a retinal top-hat profile is that currently, there is no standardised criterion for the determination of α for an arbitrary image profile, and a top-hat profile is the only one where the diameter is ‘obvious’ and well defined. For specific beam diameter definitions, the results of the model can be correspondingly scaled.

For the model, the total power of the beam equals ‘1’ without units, thus the calculated amount of power that passes through the aperture is at the same time the multiplication factor with which other power levels can be scaled.

3. Results

The results of the calculations are shown in the following figures. Note the logarithmic scale of the two input parameters far field divergence θ_σ and beam waist diameter $d_{\sigma\sigma}$. We chose a logarithmic scaling in order to be able to accurately calculate and show dependencies for small waist diameters and small divergence values in more detail than the less frequent high divergence and large beam waist diameter values. In this logarithmic representation, constant beam parameter products (basically $d_{\sigma\sigma} \cdot \theta_\sigma$) lie on a diagonal straight line and therefore the restriction of the beam waist diameter and divergence values to M^2 values between 1 and 1000 are also seen as diagonal lines (the limit for $M^2 = 1$ was calculated for a wavelength of 400 nm and the limit for $M^2 = 1000$ was calculated for a wavelength of 1400 nm to result in the broadest range of values possible for the retinal hazard wavelength range).

The second moment (2^{nd} M.) beam waist diameter was varied over the range of 0.01 mm to 100 mm (10 μm to 10 cm) and the far field divergence was varied over the range of 0.1 mrad to 500 mrad, however, as long as they were within the range of M^2 between 1 and 1000.

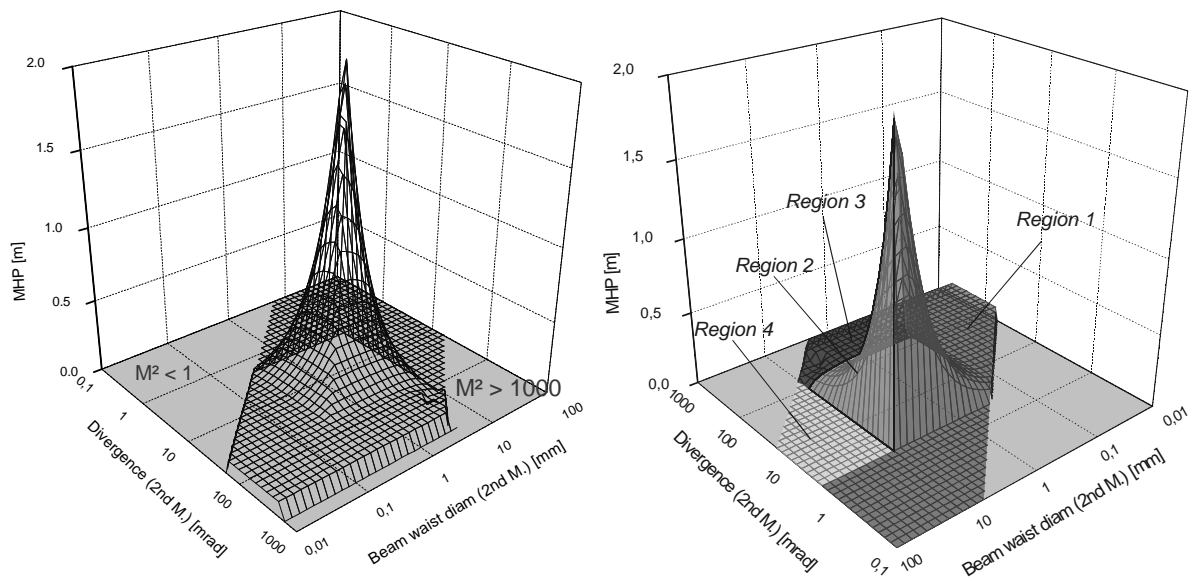

Fig. 2: The distance from the most hazardous position MHP to the beam waist – 3D plot shown with two different orientations.

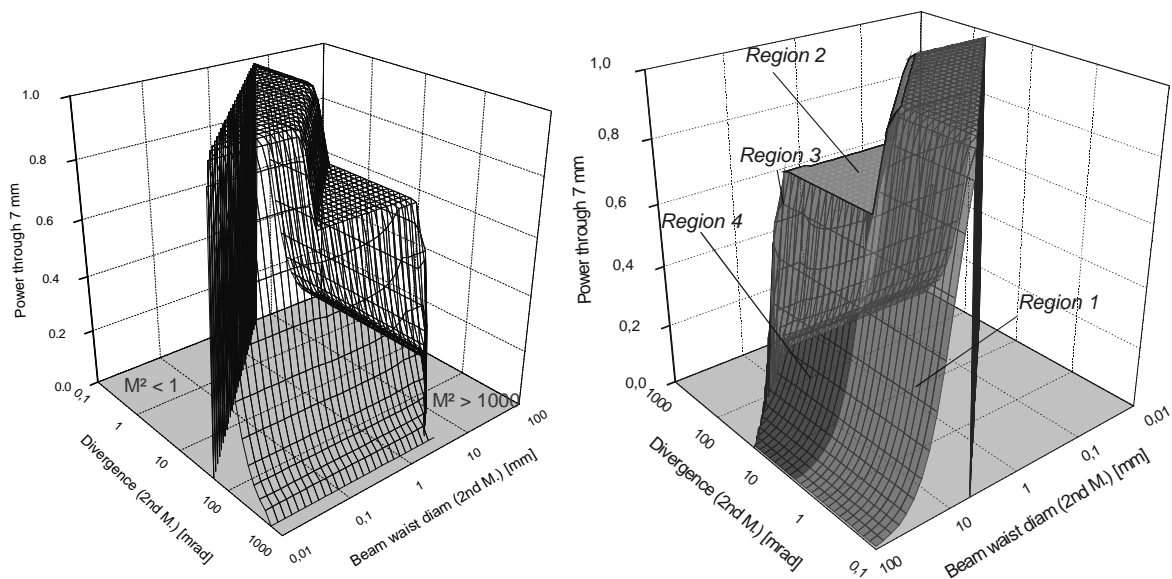

Fig. 3: The fractional power that passes through the 7 mm pupil at the most hazardous position.

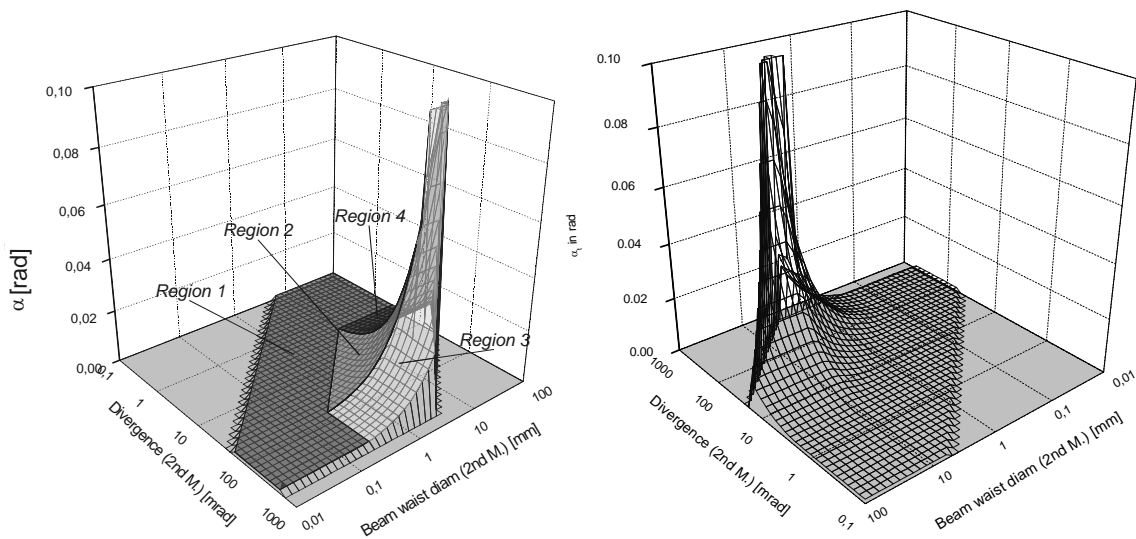

Fig. 4: The angular subtense of the apparent source α at the most hazardous position.

4. Discussion

The results of the calculations can be understood when it is considered that for Gaussian beams, the location of the apparent source [5] is the centre of curvature of the wavefront that is incident on the eye and the beam diameter at the position of the centre of curvature of the wavefront also can be used to calculate the angular subtense of the apparent source, as is discussed in [1] and in the previous paper of these proceedings.

In the far field, i.e. sufficiently far outside of the Raleigh range, the wavefront is close to a spherical one which originated at the location of the beam waist, so that for this condition, the beam waist position is a good approximation for the location of the apparent source. Therefore, for positions of the eye in the far-field, the angle that is subtended by the beam waist is the angular subtense of the apparent source α . For positions closer to the beam waist, the wavefront becomes flatter and the “apparent source” of the wavefront that is incident on the eye moves away from the location of the beam waist. For an eye located in the beam waist, the smallest retinal spot size is obtained when the eye is relaxed and images the beam profile at infinity, which means that α equals the beam divergence (corrected for the different diameter definitions for the beam divergence and α).

In order to identify and understand the dependence of the MHP, additionally to the angular subtense of the apparent source as function of position in the beam, the power P that passes through a 7 mm aperture for the different positions in the beam need to be considered. For beam diameters sufficiently smaller than 7 mm, practically the total power passes through the aperture. Therefore, around a certain range around the beam waist, moving the aperture (and the eye) away from the beam waist reduces P relatively little, however, α (being the angle that is subtended by the beam waist) decreases linearly with greater distances of the eye from the beam waist, decreasing the limit. Thus the overall level of hazard, the ratio of P over the limit (or in relative terms, P/α), increases with increasing distance to the beam waist as P more or less remains unchanged but α decreases with distance. This holds up to the position where the beam diameter approaches the diameter of the aperture, which constitutes the MHP, as for

distances beyond that point, the decrease of the power that enters the eye outweighs the decrease of α .

If a (hypothetical) beam would have sharp edges (i.e. a top-hat profile) then in the far-field, the beam could be well approximated by a cone with opening angle θ_σ and the peak of the cone located at the beam waist. The MHP would be simply the furthest distance from the beam waist where the full beam passes through the 7 mm aperture, i.e. the MHP would be where the beam diameter equals 7 mm. For further distances, the power that passes through the aperture would be reduced proportional to the square of the distance increment, while the angular subtense of the beam diameter (and thus α) is reduced only linearly. For Gaussian beam profiles, where there is no sharp edge, the model (which can also be derived analytically) shows that the MHP is where the beam radius in 2nd moment terms is somewhat larger than the 7 mm aperture, namely 8.8 mm so that 72 % of the total power passes through the 7 mm pupil. When compared to above figures and to figure 5, we have just described the ‘central’ region in terms of waist diameter and divergence, which is denominated with ‘Region 2’. However, there is also a region of small beam waist diameters and/or small divergence values, where the minimal retinal spot size at the most hazardous position (and therefore for any exposure position) remains below α_{min} . This region is marked as ‘Region 1’, which can be best discussed in detail when subdivided into three regions as discussed further below.

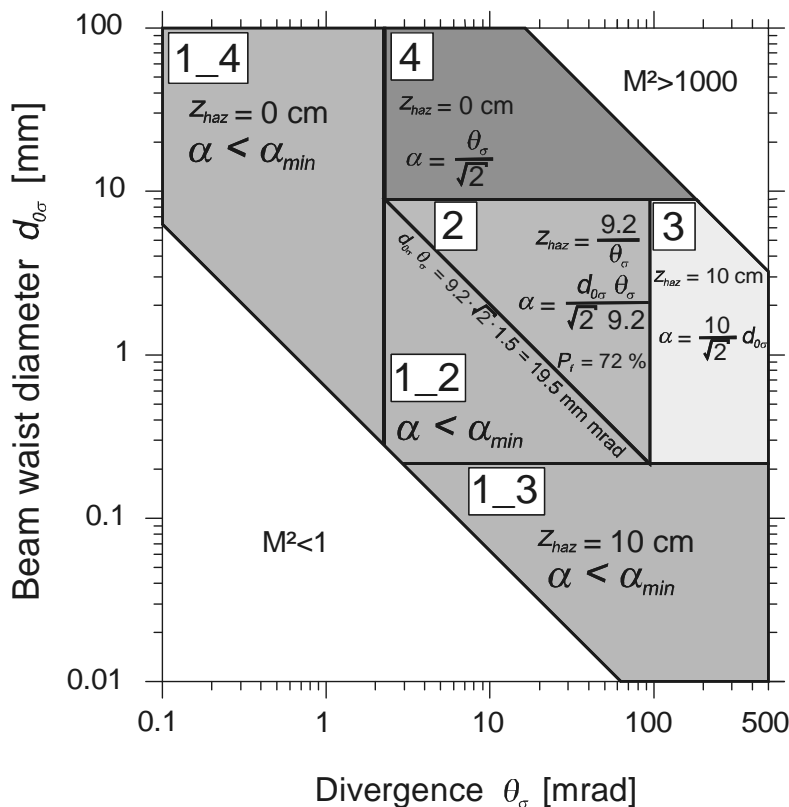

Fig. 5: A number of distinctive regions of ‘beams’ in terms of beam divergence and beam waist diameter can be distinguished, each of which can be understood on the basis of the dependence of the ratio of the power that passes through a 7 mm pupil and the angular subtense of the apparent source a on the position in the beam.

For divergence $\theta_\sigma > 0.9$ rad and waist diameters $d_{0\sigma} > 0.21$ mm, Region 3, covers beams where the MHP is at 10 cm from the beam waist, the near point of the eye, and the beam

diameter at 10 cm is larger than 8.8 mm, depending on the divergence. If the eye could accommodate to closer positions than 10 cm, region 2 would be continued also for divergence values above 0.9 mrad, however, with a near point of 10 cm, the retinal spot increases for smaller distances to the beam waist as 10 cm and this makes the exposure less hazardous, even though more power would pass through the 7 mm pupil at distances closer to the beam waist. The angular subtense of the apparent source is given again by the angular subtense of the beam waist, i.e. the eye images the beam waist to produce the smallest retinal spot (for beams with such high irradiances, the distance of 10 cm from the beam waist is in the far field).

For divergence values larger than $1.5 \cdot \sqrt{2} = 2.1$ mrad and beam waists larger than 9 mm, *Region 4* covers the case where the worst case position is the beam waist and α is equal to the divergence (corrected for beam diameter definition) $\alpha = \theta_{\sigma} / \sqrt{2}$, as the minimal retinal spot is achieved by a relaxed eye that 'images' infinity. Therefore α does not depend on the beam waist diameter, but the power that passes through the 7 mm aperture located at the beam waist obviously does.

The three regions 2, 3 and 4 are ones where α at the most hazardous position is larger than the minimal angle of 1.5 mrad and thus the correction factor C_6 is larger than 1. Region 1 is defined by a retinal spot size which is less than 1.5 mrad, i.e. $\alpha = \alpha_{\min}$ and can be subdivided into three subregions, depending on which other region where $\alpha > \alpha_{\min}$ they border. In *Region 1_2*, the location z in the beam where $\alpha = \alpha_{\min}$ (the angular subtense of the waist diameter equals $1.5 \cdot \sqrt{2} = 2.1$ mrad) is closer to the beam waist than the position where beam diameter equals 8.8 mm. Thus at the position where $\alpha = \alpha_{\min}$, the power that passes through 7 mm is higher than 72 % and is actually 100 % for most cases (the top plateau in the 3D power figure 3). Thus the MHP can be approximated well by the formula $z_{\text{haz}} = d_{0\sigma} / 2.1$ mrad where z_{haz} is in metres while $d_{0\sigma}$ is in mm. However, for cases where the beam diameter at this MHP is small enough, distances beyond the MHP have the same relative thermal hazard level, as α remains at α_{\min} and the power that passes through the 7 mm pupil is still practically 100 %.

For beams in *Region 1_4*, the beam divergence is so small that even the relaxed eye (which usually produces the largest retinal spot when the eye is on the diverging side of the beam waist) produces a retinal spot which is below the minimal value of 1.5 mrad, i.e. $\alpha = \theta_{\sigma} / \sqrt{2} < 1.5$ mrad so that $\theta_{\sigma} < 2.1$ mrad. Since α is 1.5 mrad for all exposure positions, the maximum hazard is achieved by placing the 7 mm aperture in the beam waist.

Region 1_3 covers beams with waist diameters less than 0.21 mm, so that at a distance of 10 cm from the waist, the angular subtense of the waist is less than $1.5 \text{ mrad} \cdot \sqrt{2} = 2.1$ mrad. The power that passes through a 7 mm aperture located at 10 cm from the beam waist depends on the beam divergence.

Sample beams and corresponding formulas for three of the regions are shown in figure 6.

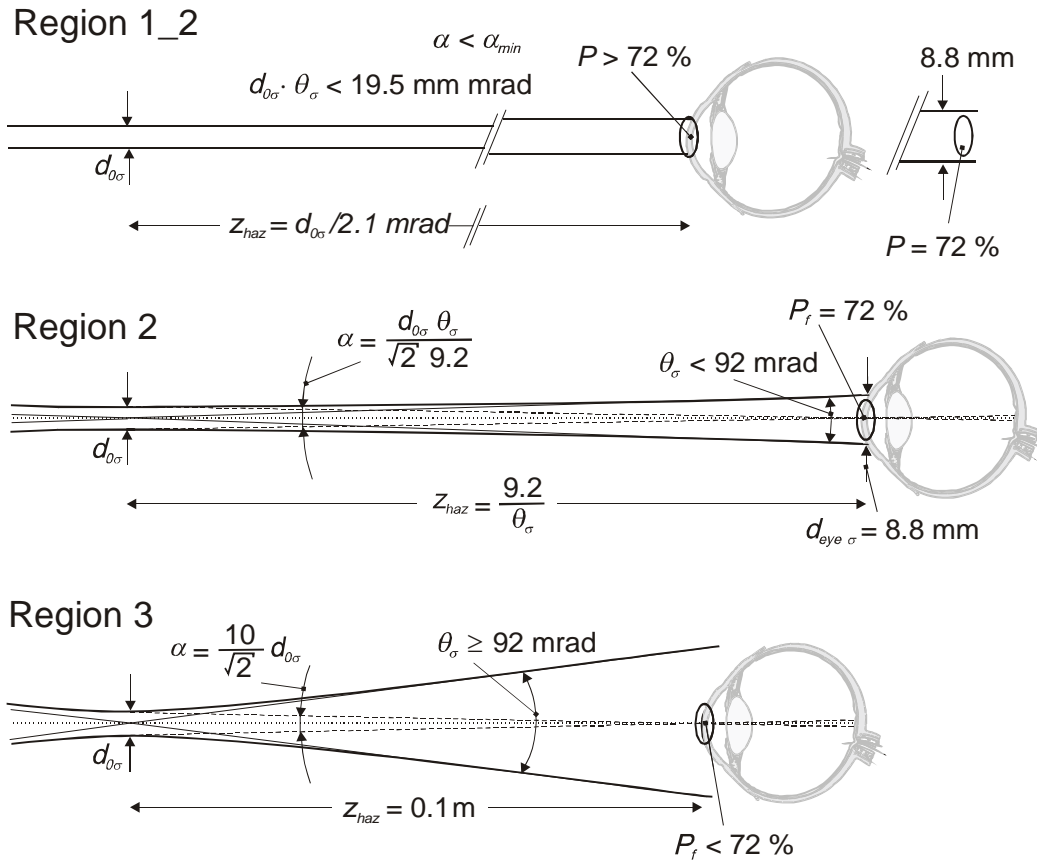

Fig. 6: Schematical of the most hazardous position for a beam with varying divergence. The beam waist diameter is specified according to the second moment method is denoted by $d_{0\sigma}$. The formulas are simplifications that are derived by assuming that the beam waist is the apparent source and approximate the model calculations very well.

The results show that for beams with a beam parameter product $d_{0\sigma} \cdot \theta_{\sigma}$ less than 19.5 mm mrad (which can be transformed with the wavelength into respective M^2 values), the angular subtense of the apparent source assumes the minimal value of 1.5 mrad. For 532 nm this would for instance translate to an M^2 of 29, for 1064 nm to an M^2 of 14.4.

5. Limits of the Model

Although the beam propagation model accurately describes the envelope for any beam, not only for a zero order Gaussian beam, when the beam diameter and divergence is determined with the second moment method, the second moment beam definition unfortunately can grossly underestimate the power that passes through an aperture and is also not appropriate criterion to determine α for a given retinal irradiance profile other than a Gaussian, as was discussed in the previous paper in these proceedings. The model can also clearly not be used for multiple sources where usually the single source is the critical case. For higher order beams and even Gaussian beams with some diffraction rings that result from passing through an aperture, the second order beam diameter and thus the results of this model may seriously underestimate the hazard and the maximum hazard position and the angular subtense of the apparent source at that position needs to be determined experimentally, if a value of $C_6 > 1$ is to be used.

6. Acknowledgements

We would like to thank Bernd Eppich from TU Berlin for offering a critical view on the limitations of the second moment beam diameter method, and Brooke Ward for sensitizing IEC Technical Committee 76 for the possibility to apply the beam propagation method to laser safety analysis which motivated us to develop the model. We gratefully acknowledge financial support from the Austrian Ministry of Innovation and Technology.

7. Literature

- [1] Henderson R, Schulmeister K, *Laser Safety*, Institute of Physics Publishing, Bristol (2004)
- [2] Pedrotti F L Pedrotti L S *Introduction to Optics*, Prentice-Hall New Jersey (1993)
- [3] ISO 11146 *Lasers and laser-related equipment – Test methods for laser widths, divergence angle and beam propagation factor*, ISO, Geneva (2003)
- [4] Ward B A, Measurement of laser and LED beams for prediction of angular subtense *International Laser Safety Conference 2003 Conference proceedings*, Orlando, LIA, (2003)
- [5] Galbiati E Evaluation of the apparent source in laser safety *Journal of Laser Application* 13 141-149 (2001)
- [6] IEC 60825-1 *Safety of laser products – Part 1: Equipment classification, requirements and user's guide*, Edition 1.2, IEC Geneva (2001)

Quellenangabe

Beam propagation model for the hazard evaluation of Gaussian laser beams

Karl Schulmeister, Sandra Althaus, Ulfried Grabner, Georg Veas

Nichtionisierende Strahlung – Sicherheit und Gesundheit

36. Jahrestagung des Fachverbandes für Strahlenschutz gemeinsam mit Schweizerische Unfallversicherungsanstalt, Nederlandse Vereniging voor Stralingshygiene, Österreichische Unfallversicherungsanstalt, Berufsgenossenschaft der Feinmechanik und Elektrotechnik Fachhochschule Köln

31. August – 2. September 2004, Köln

Band II, Seite 793-802, Bandherausgeber: Hans-Dieter Reidenbach, Klaus Dollinger, Joachim Hofmann

ISSN 1013-4506, ISBN 3-8249-0901-4

© TÜV-Verlag GmbH, Köln 2004

Veröffentlicht vom Fachverband für Strahlenschutz, Mitgliedsgesellschaft der International Radiation Protection Association (IRPA) für die Bundesrepublik Deutschland und die Schweiz